

Neon® GAS
Manual



Content

1.	Neon® Gas	6
1.1.	General and safety instructions	6
1.2.	Warranty conditions	7
1.2.1.	Transport damages	7
1.2.2.	Application	7
1.2.3.	Intended use	8
1.3.	Feature	8
1.4.	Technical Data Neon®	10
2.	Instructions for installation and connections	11
2.1.	Dimensions	11
2.2.	Installation panel-mounted housing	11
2.3.	Installation wall-mounted housing	12
2.4.	Installation of sensor	13
2.5.	Connections	14
2.5.1.	Connection diagram	14
2.5.2.	SD card	16
3.	Operation	17
3.1.	Desktop	17
3.2.	Touch screen operation	17
3.2.1.	General	17
3.2.2.	Main menu	17
3.2.3.	Submenus	17
3.3.	Settings	17
3.4.	Menu overview – where to look?	21
3.5.	Menu appearance depending on code and options	23
4.	Code	24
5.	Analog input – gas measurement	25
6.	Menu Cal – Zeropoint calibration	26
6.1.	Calibration – zeropoint	26
6.2.	Calibration – info	26

Content

7.	Digital inputs	27
8.	Test menu	28
9.	Memory	29
9.1.	Store and upload settings	29
9.1.1.	How to save settings	30
9.1.2.	How to load settings	31
9.2.	Software update	32
9.3.	How to save the diagnosis file	33
10.	System functions	34
10.1.	Language	34
10.2.	Time	34
10.3.	Display	35
10.3.1.	Settings	35
10.3.2.	Touch Cal – for instruments with touch screen	36
10.4.	Contact	37
10.5.	Event-related support	38
10.6.	Info	39
10.7.	Reset to factory settings	40
10.8.	Add-on activation	41
11.	Alarm relay	42
11.1.	Settings	42
11.2.	Alarm action	43
12.	Add-on Datalog	44
12.1.	View logged data	46
13.	Add-ons mA output	47
14.	Add-on Modbus RTU	48
14.1.	How to read out data	48
14.2.	Communication parameters	49
14.3.	Registers	49
14.3.1.	How to read variables	50
14.3.2.	Measured values, controller outputs and status of digital inputs and outputs	51
14.3.3.	Event messages and calibration results	52

14.3.4.	Instrument data	55
14.3.5.	How to read and write parameter settings	56
14.3.6.	Units and texts	62
14.3.7.	Test functions	65
15.	Operation and Maintenance of Neon® Gas	66
15.1.	Start-up	66
15.2.	Maintenance of the measurement	68
15.2.1.	Calibration of the measurement	68
15.2.2.	Zeropoint calibration	68
15.2.3.	Testing the safety features	69
15.3.	Decommissioning and disposal	69
15.4.	Facilitating functions	69
15.4.1.	Store and load settings via SD card	69
15.4.2.	Software update via SD card	69
15.4.3.	Test menu	69
16.	Trouble-Shooting	70
16.1.	Useful accessories for trouble-shooting	70
16.2.	Contact	70
16.3.	Diagnosis file	70
16.4.	Info	71
16.5.	Event messages	71
16.6.	Eventlog	72
16.7.	Event help	72
16.8.	Events with Popup messages	75
16.9.	Reset	76
	Index	77

1. Neon® Gas

1. Neon® Gas

is a product by Kuntze Instruments GmbH which offer high quality and long-term reliability, made in Germany.

With its modular design, the Neon® Gas warning instrument can be tailored to your application. The entry-level version contains two inputs for measurement, two digital inputs, and an alarm relay.

A set of codes allows access to different operation levels. If you want to ensure that only authorized personnel can operate the instrument, define an auto-lock time after which the code is reset to default setting.

Save energy with the Eco mode, in which the display illumination is deactivated after an adjustable interval.

The instrument has an SD card slot. You can store and load instrument settings, to duplicate software settings to additional instruments or to reinstall your settings after updates or repair. You can also use the SD card for software updates.

We have equipped the Neon® instruments with some very convenient features:

The touch screen for example is the perfect complement to the graphical operation and gives you shortcut access to important menus from the main display.

Test functions make trouble-shooting and installation easier by providing manual operation of all digital and analog outputs.

The Neon® instruments are expandable through software add-ons and hardware modules. You can add:

- > Up to two analog outputs
- > A datalog function that stores data on the SD card
- > Modbus RTU interface

Control your water quality at any time, from any place, on any device. The solution is Kuntze Cloud Connect®.

With Neon® Gas you have certainly made the right choice. On the following pages find out more about the instrument. If you have further questions or are looking for information not included in this manual or if you are interested in supplementing products such as sensors, just give us a call – we will be delighted to help you!

1.1. General and safety instructions

This operation manual applies to the following instruments

Instrument type Neon® Gas

SW version V 3.25

The manual contains technical information on installation, operation, and maintenance.

Keep this manual in a place where you can always look up the safety instructions and the information on handling and usage. According to DIN 61010 the manual is part of the product and has to be preserved as long as the instrument is used, and given to the new owner if the instrument is sold.

The instrument was designed, built, and tested according to the directives for electronic devices and has left our company in perfect working condition. To preserve this condition and to ensure safe operation, follow all instructions carefully and pay special attention to all warnings issued in this manual. If the instrument is visibly damaged or has been stored inappropriately or if there are any doubts concerning safe operation, shut it down and make sure it cannot be restarted.

You will notice that certain safety instructions are highlighted:

- Warning** **highlights instructions for the protection of people. Disregarding warnings may cause accidents and injuries!**
- Attention** **highlights instructions for the protection of the instrument and equipment. Disregarding these instructions may lead to damage or destruction of the instrument or equipment!**
- Note** **is used to highlight interesting details.**

1.2. Warranty conditions

We have to point out that the warranties specified in our trading conditions are valid only if the following conditions are met:

- > Installation and start-up by Kuntze personnel or trained and authorized technicians
- > Maintenance of instrument and peripheral equipment according to the instructions of this manual
- > Use according to the designation specified on the following pages
- > Use of original accessories and spare parts only
- > Observance of operation conditions and settings according to this manual

Warranty is void if any one of the conditions listed above is disregarded.

1.2.1. Transport damages

Please check for damages immediately after delivery and report any damages within 24h to the delivering company. Never work with a damaged instrument!

1.2.2. Application

Neon® instruments can be used for the following measurements:

Instrument	Measurement
Neon® pR	pH or ORP and temperature
Neon® DIS	Free Chlorine, Chlorine dioxide, Ozone, Hydrogen peroxide, or Total Chlorine and temperature
Neon® EC IL	Inductive conductivity and temperature
Neon® EC	Conductive conductivity and temperature
Neon® GAS	Gas monitoring for Chlorine, Chlorine dioxide and Ozone gas

1. Neon® Gas

Warning **The instrument checks the input signals, test and calibration results. It cannot detect erroneous settings or failures in the system, nor can it check for plausibility! The safety of the system of which the instrument is part of lies within the reach of responsibility of whoever built the system!**

1.2.3. *Intended use*

Use these instruments only for the monitoring of ambient air.

Use only sensors, assemblies, and accessories made by Kuntze, and make sure that they fit your application.

Install and operate the instrument according to this manual. Carry out all steps described, and check all measurements and settings before you activate the controller.

Use all available safety measures such as the alarm relay and the 22mA alarm current.

Regularly check that all safety measures are in good working condition!

Warning **The protection built into the instrument is impaired if it is not used as intended!**

1.3. **Feature**

Basic instrument GAS	
Measuring ranges	
Chlorine gas	0- 10.00 ppm
Ozone gas	0- 1.00 ppm
Chlorine dioxide gas	0- 1.00 ppm
Display	2 x measured value
Operation	Touch screen
Calibration	Zeropoint calibration List of the last 10 calibration results
Measurement	2 inputs for gas sensors: Chlorine, Chlorine dioxide and Ozone display in ppm
Relay 3 – alarm relay	Potential-free contact 6A, 250 V, max. 550VA Alarm events selectable via menu Min. and max. limits and adjustable delay
Digital input 1 + 2	To confirm of limit value alarm e.g. via door contact Input can be set to N/O or N/C contact via menu
Test menu	Operation of relays and outputs

Basic instrument GAS	
SD card	To load and save settings To save the diagnosis file To load software updates
Auto lock	Resets the code to 0000 after a defined period of time
Eco mode	Saves energy by deactivating the display illumination after an adjustable interval
Eventlog	Stores up to 100 events
Event help	Provides help for current events
Add-on	Functions can be added via code
Add-ons	
Analog output 1	0/4.. 20 mA galvanically isolated, max. load 500 Ohm 22 mA alarm current selectable via menu Scaleable within the measuring range
Analog output 2	0/4.. 20 mA galvanically isolated, max. load 500 Ohm 22 mA alarm current selectable via menu Scaleable within the measuring range
Data log	Measured value 1+2 selectable Interval adjustable between 1 second and 24 hours Ring or Stop mode
Digital interface	Modbus RTU, 19200 bps, 8 Bit, 1 Stopp-Bit and parity even

1. Neon® Gas

1.4. Technical Data

Feature		
View		
Installation	panel-mounted housing (max. wall thickness: 5mm)	wall-mounted housing
Dimensions	138 x 138 x 83 mm	144 x 144 x 156 mm
Weight	0.6 kg	1.0 kg
Connections	Cable inlet: 2x M16, 2x M12 Terminals Basic function: rigid/flexible 0.2 - 2.5 / 0.2 - 2.5 mm ² Measurements: rigid/flexible 0.2 - 1 / 0.2 - 1.5 mm ²	
Protection class	Front IP54	IP65
Power supply	85.. 250 V AC, +6/-10%, 40.. 60Hz Option: 24 V DC	
Power consumption	10 VA	
Power supply	85.. 250 V AC, +6/-10%, 40.. 60Hz Option: 24 V DC	
Power consumption	10 VA	
Contact rating	3 relays, potential-free N/O contacts, max. 250 V, 6A, 550 VA	
Operation temperature	0.. 50°C	
Storage temperature	-20.. +65°C	
Rel. Humidity	max. 90% rH at 40°C (non-condensing)	

2. Instructions for installation and connections

Attention **Install the instrument in a place where it is not put under mechanical or chemical strain!**

Note **Mind the protection class!**

2.1. Dimensions

Dimensions panel-mounted housing:

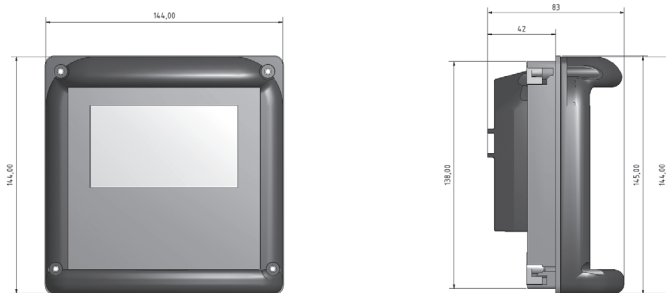

Picture 2 Dimensions wall-mounted housing:

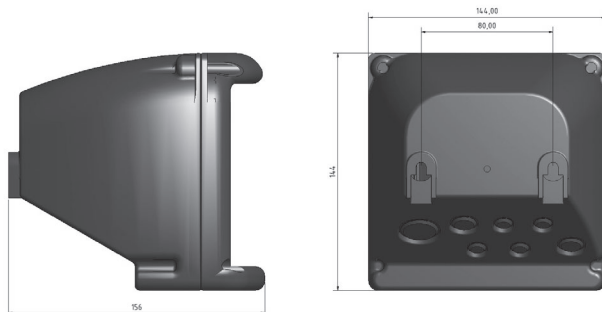

2.2. Installation panel-mounted housing

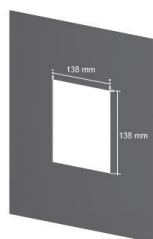

Prepare an opening of 138 x 138 mm. Clip the installation frame into the opening.

(max. wall thickness: 5 mm)

2. Instructions for installation and connections

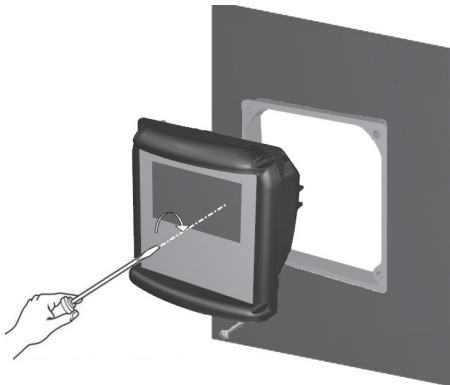

Place the instrument inside the frame and secure it with the M4 x 25 screws. Tighten the screws until the instrument is firmly fixed.

Attention To preserve the protection class, the flat gasket of the housing and the sealing ring of the frame must be used!

2.3. Installation wall-mounted housing



Pierce the pre-cut openings of the housing for as many cable glands as you wish to use and remove any remaining pieces from the openings.

Place the installation plate into the back frame and screw in the cable glands.

Drill two holes at 80 mm horizontal distance. Screw two screws into the holes and mount the instrument on the screws.

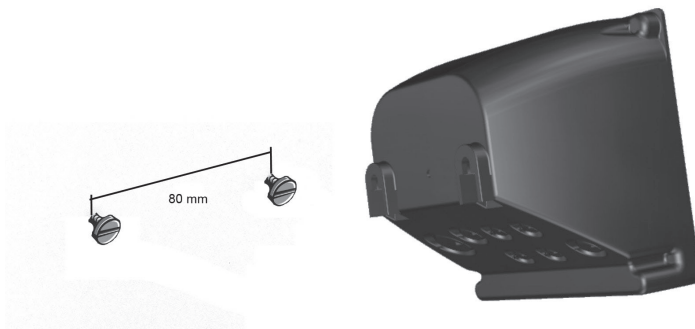

Or you can open the instrument and put the screws through the holes at the back of the instrument. Mind to replace the covers before closing the instrument.

2. Instructions for installation and connections

2.4. Installation of sensor

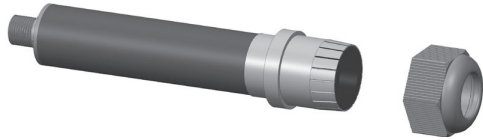

Unscrew the screwcap



Take a sensing element and remove the transport protection with the short-circuit.

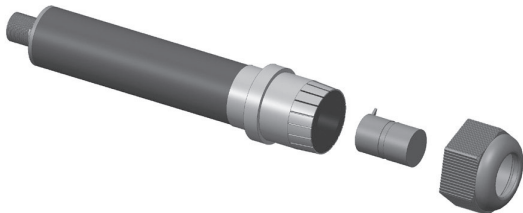

Fit the sensing element gently into the sensor. The correct position is indicated by a groove. Mind that you do not bend the connecting pins. Check the sealing ring and screw the screwcap on.



Mount the sensor with two clamps vertically, the sensing element pointing down, approx. 30 cm above the floor. Mind that the sensor is not subject to strong wind, heat, or direct sunlight. The sensing element must never get wet! Connect the M12 cable.

2. Instructions for installation and connections

2.5. Connections

A detailed connection diagram can be found on the following pages.

Before connecting the power supply check the information on the instrument label!

Warning **Input, output, and control cables must be installed separate from each other and especially apart from power lines!**

For inputs and outputs use screened cables, and connect the screens on one side only.

The measurements are interference-sensitive. Use only our special cables with a very high insulation and keep the distances as short as possible.



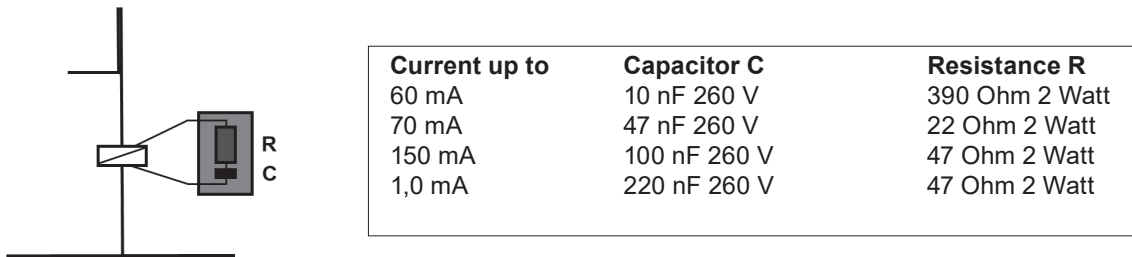

When using the relays, mind that with inductive loads, interference must be suppressed. If that is not possible, the relay must be protected at the terminal block by a resistance-capacity filter or, in case of direct current, by a free-wheeling diode.

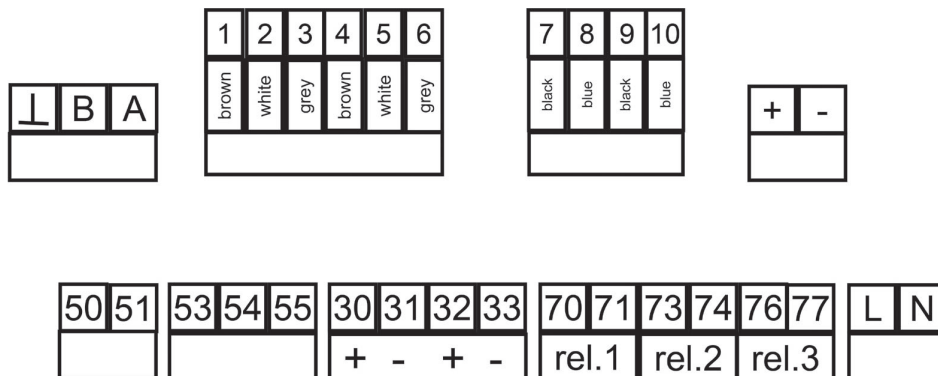

2.5.1. Connection diagram

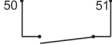

2. Instructions for installation and connections

Connection	Terminals	Notes
Gas sensor 1	1-3	1 = brown 2 = white 3 = grey
	7, 8	7 = black 8 = blue
Gas sensor 2	4-6	4 = brown 5 = white 6 = grey
	9, 10	9 = black 10 = blue
Digital input 1	50+51 	50 = +, 51 = -
Digital input 2	53-55 	53 = +, 54 = -
Analog output 1	30+31	30 = +, 31 = -, max. load 500 Ohm
Analog output 2	32+33	32 = +, 33 = -, max. load 500 Ohm
Relay 1	70+71 	Max. 2 A, AC 250 V/550 VA DC 30 V/60 W
Relay 2	73+74 	Max. 2 A, AC 250 V/550 VA DC 30 V/60 W
Relay 3	76+77 	Alarm relay Max. 2 A, AC 250 V/550 VA DC 30 V/60 W
Power supply	L+N	85-265 V AC
Power supply 24 V DC	+/-	24 V DC
Modbus RTU	A+B	A = + B = -
	⊥	⊥ = Screen

Add-ons (marked in grey)

Up to 2 mA outputs, data logging, and RS 485

2. Instructions for installation and connections

2.5.2. SD card

You will find the SD card slot at the back of the housing.

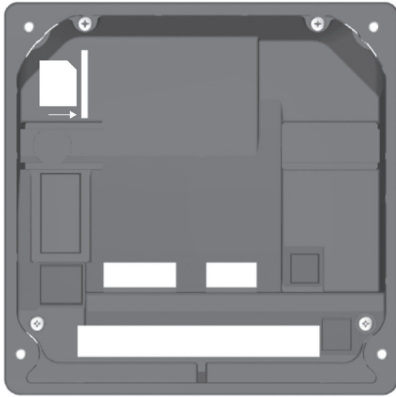

Press the SD card – with angled edge top right – into the slot until it is into place.

By pressing the SD card the mounting is loose and the SD card will be ejected.

Note **Never remove the SD card while the logging is running! Always set the mode to OFF (not stop!) before removing the card. Otherwise data loss might occur, and an error message will appear.**

3. Operation

When the power is switched on, the instrument initialises. During that process, the time is displayed.

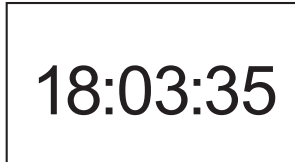

After approx. 20 seconds the process is finished, and the measured values are displayed.

3.1. Desktop

With factory settings, the display shows at the top the instrument name and the time, followed by the current measured value.

In the bottom line, the triangular symbol shows the way to the menu (key DOWN, or just touch the triangle if you have a touch screen instrument). On the right side of the bottom line, current events are displayed.

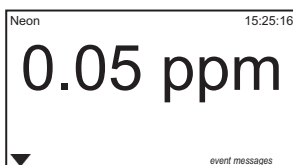

Starting from the desktop (display of the measured values), enter the menu with key DOWN.

3.2. Touch screen operation

The instrument is operated via touch screen. The screen is of the resistive type, with the advantage that a touch is recognized via pressure – it can be operated even with gloves, and does not respond to mere splashes of water. Press your finger on the screen gently but firmly, and keep the pressure until the instrument shows that the touch has been recognized.

In the desktop (display of the measured values), touching various areas of the screen gives access to different functions and submenus:



Touch

- > **time** to enter the time setting menu
- > **event message** to get suggestions for trouble-shooting
- > the **triangle** to enter the main menu

Note Mind that access might be limited via code. If the current code does not permit access to a selected area, the touch will only yield an empty display. In that case you have to enter the main menu and set a valid code first (0202 for the calibration level, 1612 for full access)

3. Operation

3.2.1. General

All submenus show on the right side of the top line two symbols:



Home – Touching this symbol takes you back to the desktop from any position



ESC – Touching ESC takes you back to the previous menu.

3.2.2. Main menu

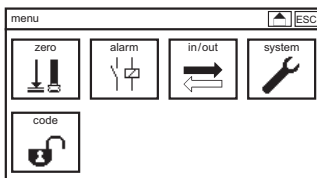

Press the triangle on the left side of the bottom line of the desktop to enter the main menu. In the main menu, select submenus by touching the corresponding symbols.

3.2.3. Submenus

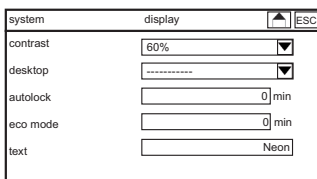

In submenus you will find on the left side the parameters and on the right side the corresponding settings. If the submenu contains more parameters than can be shown, a scroll bar on the right side gives access to the parameters currently not shown.

Move the scroll bar by pulling the bar with your finger or by touching the triangles at the top and bottom of the bar.

3.3. Settings

Parameters are set either by entering a value by selecting a setting from a drop-down list or by activating or deactivating an item from an action list, depending on the nature of the parameter.

Drop-down lists

Drop-down lists appear whenever you have to select a single option from a variety of options, for example when you choose a display design:

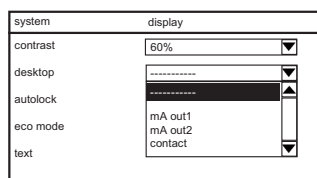

Drop-down lists are indicated by a triangle on the right side of the parameter setting.

Open the drop-down list by touching the triangle. A list of possible settings appears. Select the desired setting via touch.

Press ESC if you want to cancel and leave without changing the setting.

Action lists

Action lists appear whenever you can select more than one option from a list, for example alarm actions:

alarm	action
<input checked="" type="checkbox"/>	overrange
<input checked="" type="checkbox"/>	relay 1
<input checked="" type="checkbox"/>	relay 2
<input checked="" type="checkbox"/>	sensor error

Action lists contain all selectable items. On the left side, each item has a box that can be ticked. Press the desired option with your finger to tick or untick its box.

Note Options that are not activated in your instrument are crossed out and cannot be ticked.

Entering a value/keyboard

For settings of a freely adjustable parameter, like limit values or contact data, a keyboard appears if you select the input field – by touching the settings box of the parameter.

On the right side of the keyboard, four function keys are shown:

- > The upmost function key shows „123“ or „**abc**“ and allows changing from characters to numbers and vice versa.
- > The „**C**“ (clear) key erases the last input
- > The „**AC**“ (all clear) key erases the complete input
- > The „**OK**“ acknowledges the selection

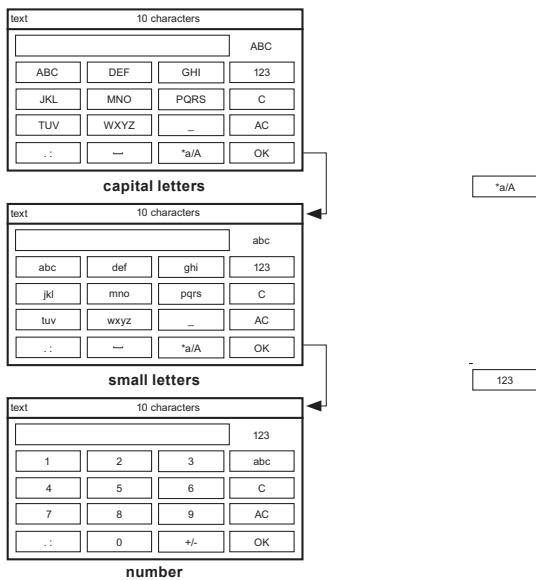

3. Operation

Note **With numerical parameters, the keyboard automatically shows only numbers.**

Select simply numbers and characters by pressing the field.

Example: abc key

abc key touch once: a appears

abc key twice: b appears

abc key three times: c appears

Touch OK when the input is complete. Now the instrument checks if the input is within the allowed limits. If it is, the new value is stored, and the setting is finished. The keyboard disappears.

If the value does not lie within the allowed limits, the value is not stored. The input field turns dark, and the keyboard remains open until you enter a correct value or cancel the setting and touch ESC or home.

Note **For maximum comfort the instrument adds zeros automatically. An input of pH 4, for example, is automatically turned into 4.00, and an input of 1 for the datalog interval is automatically interpreted as 00:00:01 (hours:minutes:seconds). Unfortunately, for date, code, add-on codes, text, and contact data, this support is not feasible.**

3.4. Menu overview – where to look?

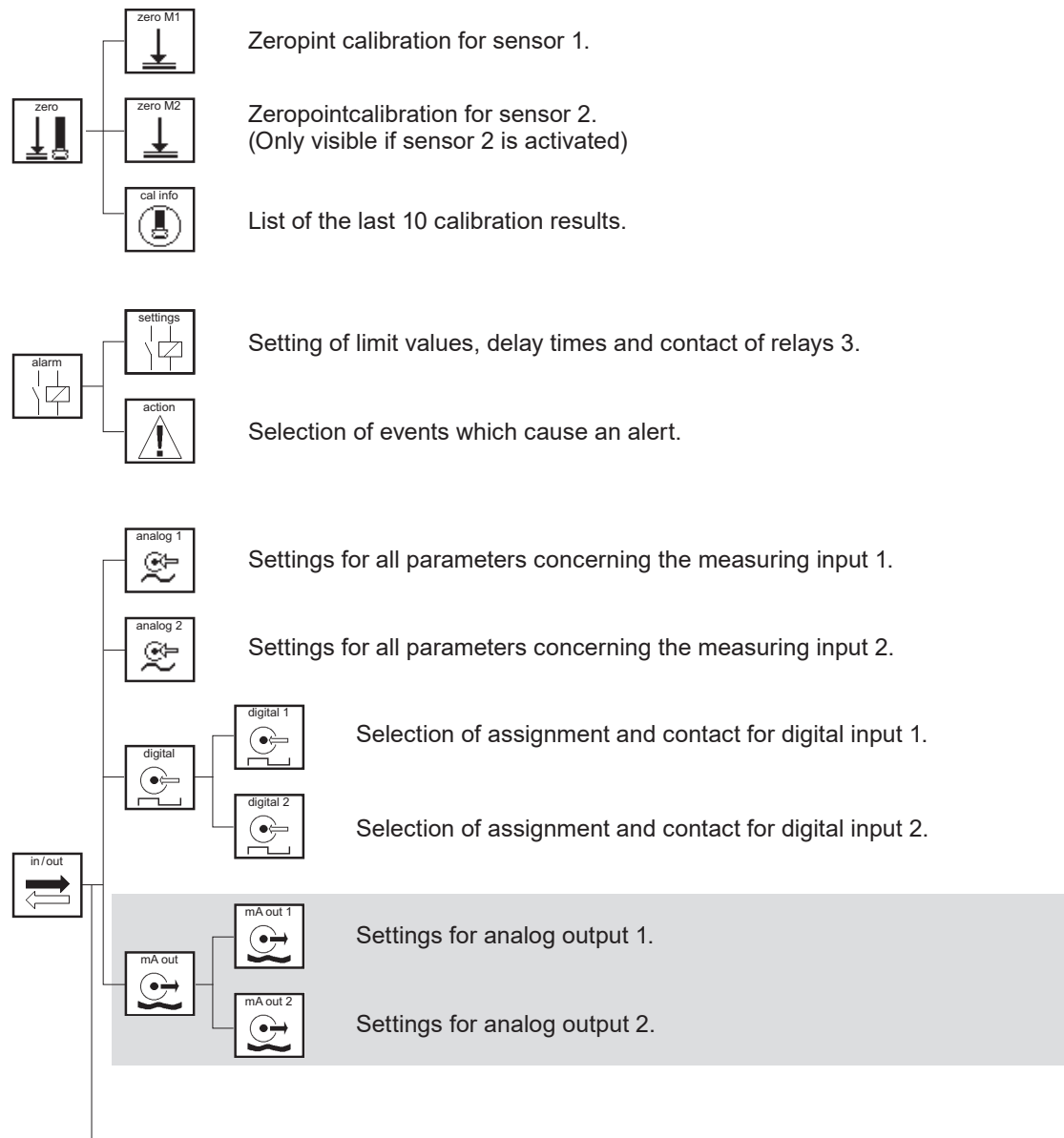

Add-ons (marked in grey)
 mA output, Datalogger and Modbus RTU.

3. Operation

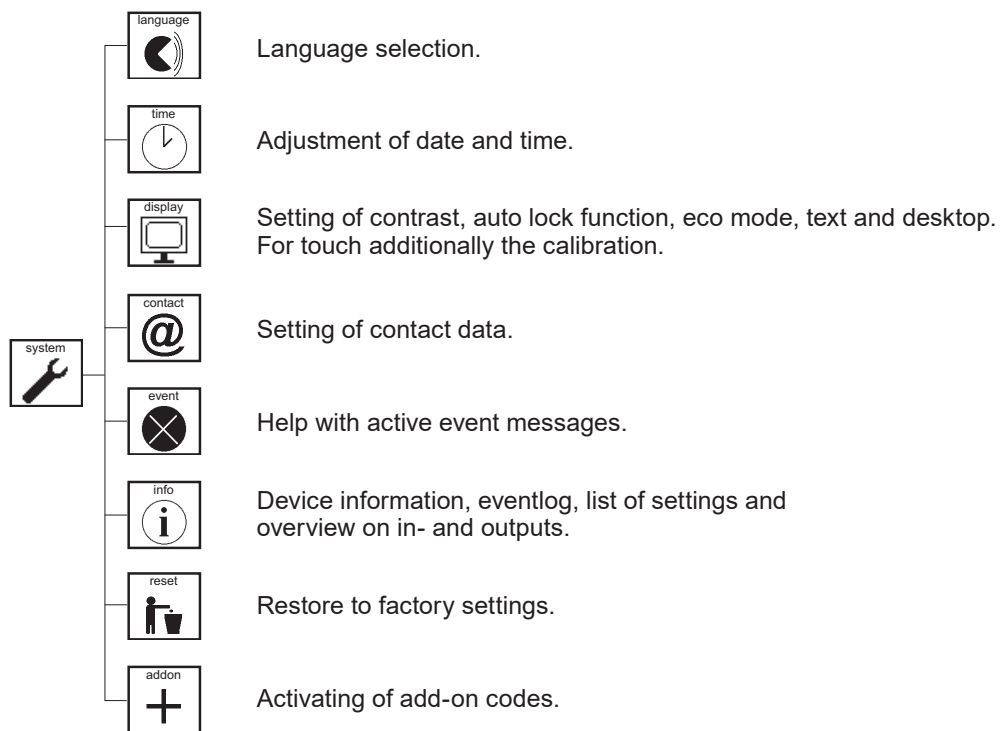
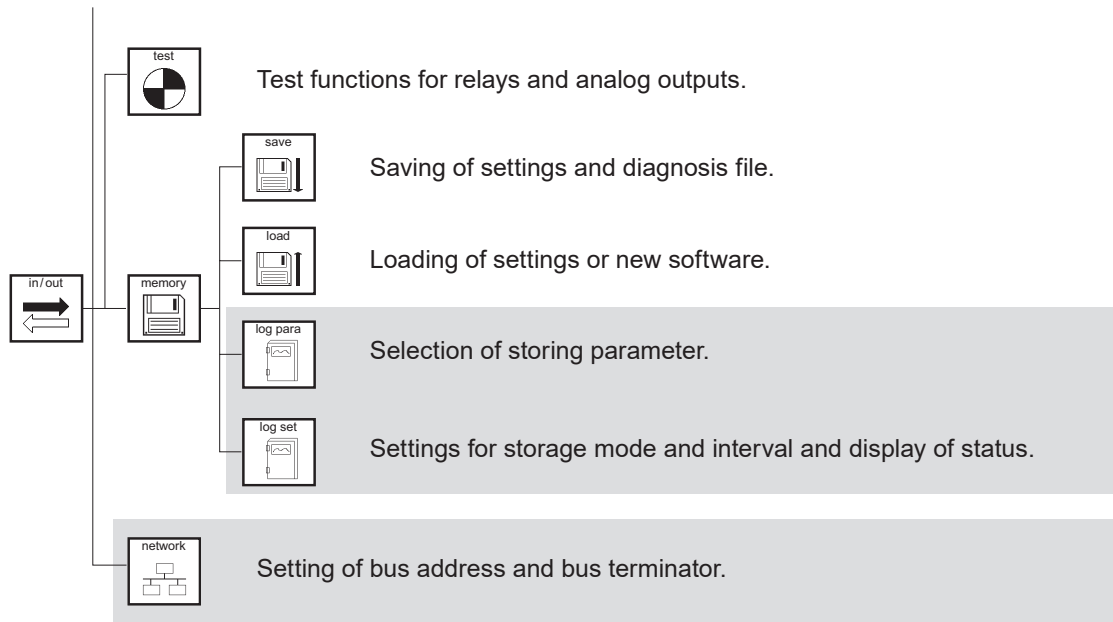

Add-ons (marked in grey)
mA output, Datalogger and Modbus RTU.

3.5. Menu appearance depending on code and options

The main menu and the submenus appear different, depending on code, add-ons, and settings.

No valid code

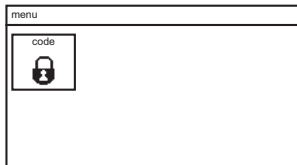

If no valid code is set, the main menu shows only one symbol to enter another code.

When the code is set to 1612 to give full access to all functions, the main menu shows all functions of the instrument. In the entry-level version the main menu shows four symbols. In the maximum version with all available add-ons, the main menu contains five symbols.

Entry-level version

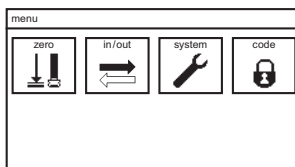

Maximum version

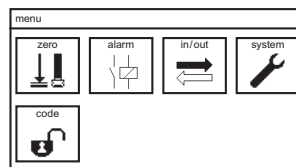

With code 0202, access is restricted, and the number of symbols decreases.

4. Code

4. Code

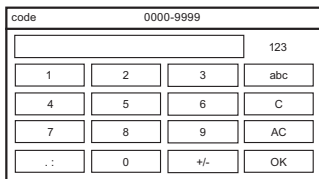
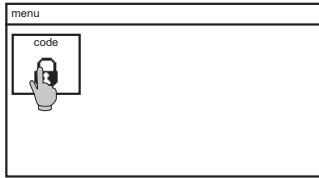

To enter a code, select the symbol CODE from the main menu, and enter the code via the keyboard.

The Neon[®] instruments have two access levels:

Calibration level code: 0202

On this level you can calibrate, save settings, events and the diagnosis file, and view various settings.

Full access code: 1612

On this level you can enter and change all functions and settings.

If the full access code is set, the CODE symbol in the main menu shows an open lock instead of a closed one.

Invalid code or calibration level



Full access

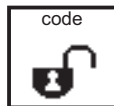

Autolock function

On delivery, the autolock function is deactivated. If you activate it via menu, the code is reset to 0000, to prevent unauthorized operation, after a defined interval without operation, or whenever the power supply was cut off. For more information, see the chapter "System functions".

5. Analog input – gas measurement

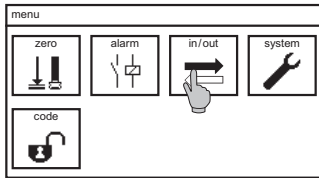

Select the symbol IN/OUT in the main menu and then the symbol ANALOG.

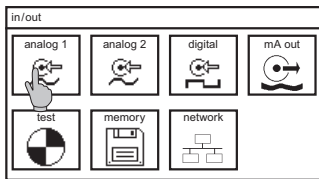

In the submenu ANALOG you can select measuring parameter, put in slope and sensor test intervall and see when the next automatic sensor test will happen.

Measure

To select the parameter, select Chlorine, Chlorine dioxide, or Ozone gas. If there is no sensor connected to measuring input 2 select no sensor otherwise an event message occurs.

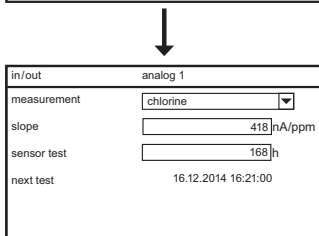

Warning

Whenever you change the measuring range, the instrument automatically changes the settings for current outputs, and limits. Check these settings after changing the measuring range!

Warning

If you read out sensor 2 via mA output and change the settings (for measuring input 2) in the ANALOG 2 menu to “No sensor” the readout of the assigned mA output is automatically reassigned to sensor 1.

Slope

Here you can set the slope written on the sensor element.

Sensor test

You can adjust the interval between subsequent tests.

Next test

Shows when the next test will take place.

6. Menu Cal – Zeropoint calibration

6. Menu Cal – Zeropoint calibration

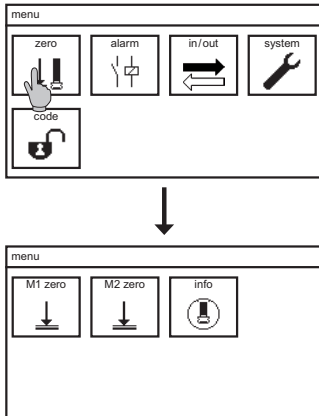

Select the symbol CAL to enter the submenu calibration. Here you find three symbols: M1 ZERO, M2 ZERO (if M2 is activated), and INFO.

6.1. Calibration – zeropoint

Warning If the zeropoint calibration is done with an extant concentration or with a reading caused by cross references the measurement is distort and a reliable measurement is not possible.

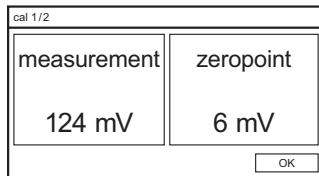

> In the CAL menu, select ZEROPOINT.

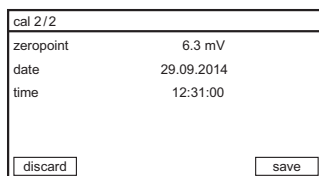

> With OK you execute the calibration and reach the info screen, showing the results of the calibration.

> With the SAVE button you store the results. With DISCARD you reject the results and keep the previous calibration values.

6.2. Calibration – info

calibration		info	
24.04.2014	14:08:56	3.3 mV	

17.03.2014	13:58:32		2.5 mV
10.02.2013	09:08:12	-1.2 mV	
30.05.2013	11:00:39		2.1 mV
31.03.2012	08:24:38	3.2 mV	

Select the symbol INFO in the CAL menu to view the last calibration results.

Note The zeropoint calibration results of sensor 1 is shown in the left column and of sensor 2 in the right column.

7. Digital inputs

All settings concerning the digital inputs are found in the submenu IN/OUT → DIGITAL. If you have two digital inputs, separate symbols will appear for them.

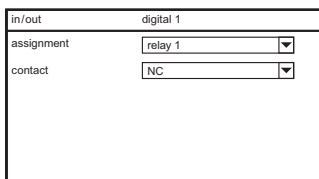
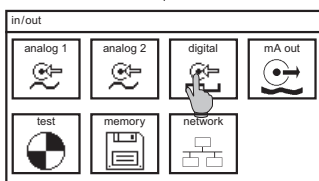
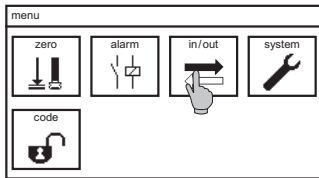

Assignment

Choose in the dropdown list which relay will be deactivated by switching the digital input.

Contact

For both inputs you can define whether the input should work as a normally open (NO) or normally closed (NC) contact.

8. Test menu

8. Test menu

The test menu always shows a list of the maximum available analog and digital outputs. Naturally, you can operate only those outputs that are activated in your instrument.

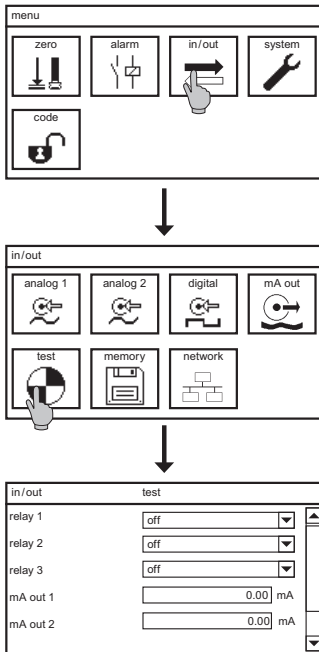

Select the symbol TEST in the submenu IN/OUT.

In the submenu TEST you can switch all available relays and define mA values for the analog outputs. To switch a relay, select ON from its drop-down list. To check an analog output, select its settings to open the keyboard. Set the output to a value between 0.00 and 22.00 mA. This value is then sent out via the selected analog output.

Note When you leave the menu, all relays and all analog outputs are reset to their previous settings.

9. Memory

In the menu MEMORY you can find all functions and settings concerning the SD card.

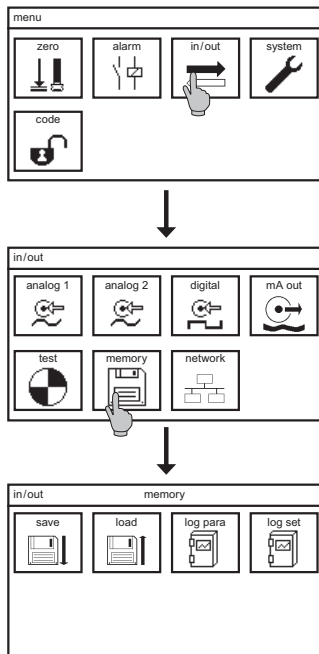

Select the symbol IN/OUT in the main menu, and then in the submenu the symbol MEMORY.

NOTE The submenus **LOG PARA** and **LOG SET** are shown only if the datalog function has been activated.

9.1. Store and upload settings

You can save all settings on the SD card, for safekeeping, or to duplicate the settings into another instrument of the same type. This way you can easily restore your settings with a new instrument, or after a software-update, or after adding additional functions. With an appropriate PC program, you can even do all settings on the PC and then load them into the Neon® instrument via SD card.

Note Settings can be duplicated only to instruments of the same type.

9. Memory

9.1.1. How to save settings

Make sure that an industry-standard SD card (max. 2 GB) with free storage space is plugged into the instrument.

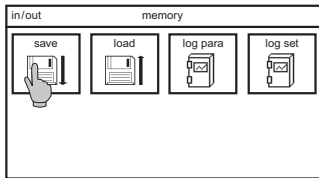

In the menu IN/OUT →MEMORY select the symbol SAVE.

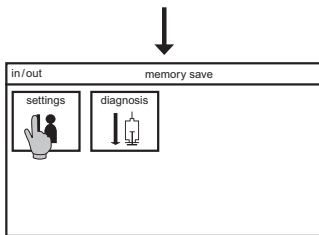

Select the symbol SETTINGS.

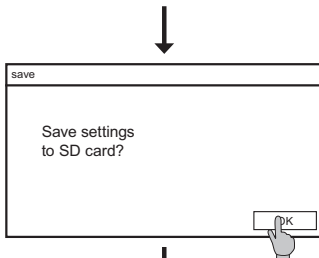

Acknowledge with OK.

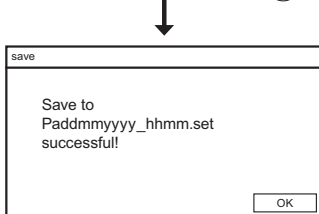

The display shows the name of the created file. The name consists of the parameter and the date. Acknowledge with OK.

9.1.2. How to load settings

Make sure that the SD card with the settings-file is plugged into the instrument.

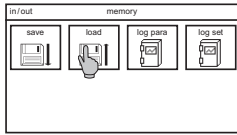

In the submenu MEMORY select the symbol LOAD.

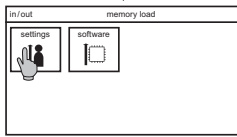

In the submenu select the symbol SETTINGS.

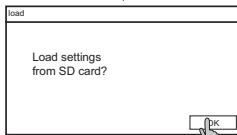

Acknowledge with OK.

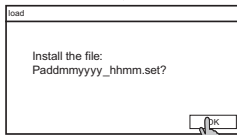

The display shows the name of the file that will be loaded. The name consists of the parameter and the date. Acknowledge with OK.

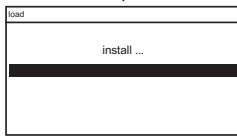

Progress is indicated by a status bar.

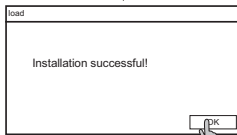

Acknowledge with OK.

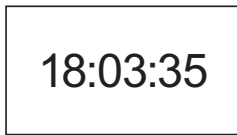

After installation, the instrument initializes. During that process, the time is displayed on the desktop.

Note You can only load settings files for the same parameter.

9. Memory

9.2. Software update

For a software-update we will send you two files. Save both files on an industry-standard SD card – directly, use no subfolder! Plug the SD card into the instrument.

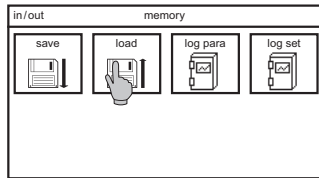

In the submenu MEMORY select the symbol LOAD.

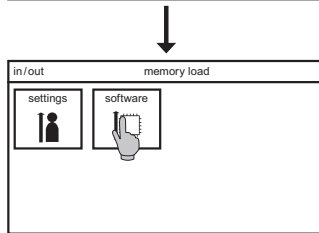

Select the symbol SOFTWARE.

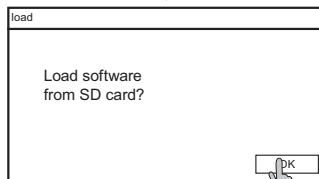

Acknowledge with OK.

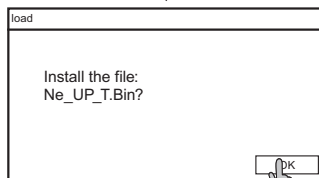

The display shows the name of the file that will be loaded. Acknowledge with OK.

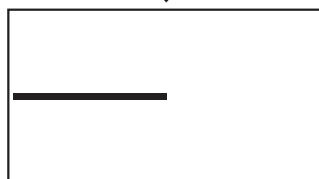

Progress is indicated by a status bar.

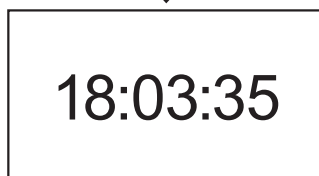

After installation, the instrument initializes. During that process, the time is displayed on the desktop.

9.3. How to save the diagnosis file

If the measurement does not run as planned, it is useful to assess the situation by checking all settings and current values. To collect all the information and maybe have it ready for a contact person, you can save a diagnosis file on the SD card.

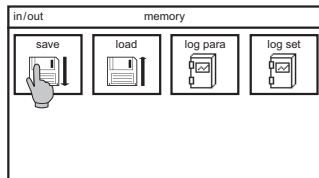

In the submenu MEMORY select the symbol SAVE.

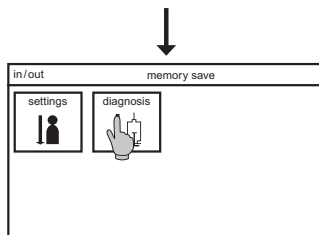

Select the symbol DIAGNOSIS.

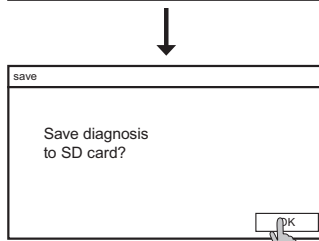

Acknowledge with OK.

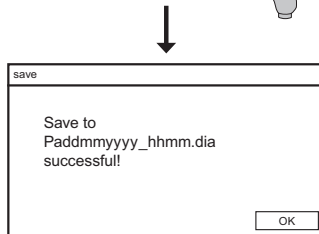

The display shows the name of the created file. The name consists of the parameter and the date. Acknowledge with OK.

Note The **.dia** file is a binary file and can only be read with an appropriate configuration program.

10. System functions

10. System functions

Note System settings can only be changed with the full access code.

10.1. Language

For the menu, a variety of languages are available. The entry-level version contains English and German.

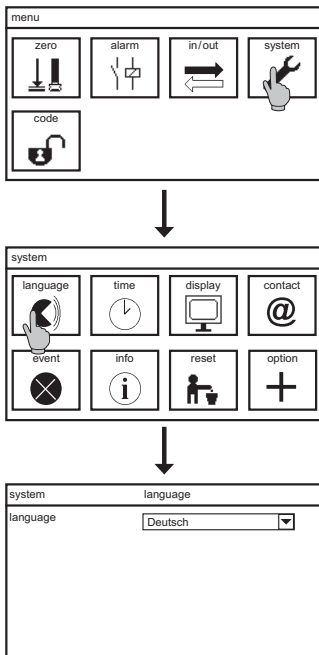

To change the language, select the symbol SYSTEM in the main menu and in the submenu the symbol LANGUAGE. A drop-down list shows all languages that are available on your instrument.

10.2. Time

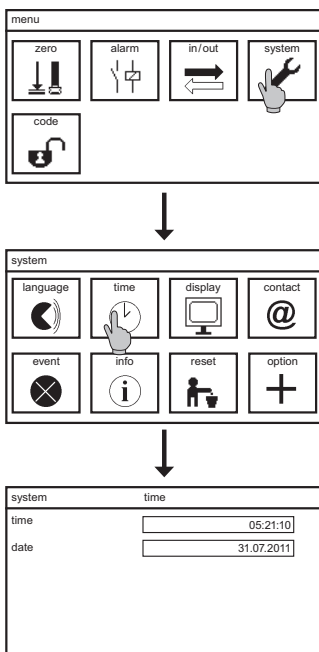

To set the internal clock, select the symbol SYSTEM in the main menu, and in the submenu the symbol TIME.

When you select the field of either time or date, a keyboard appears to enter the desired time or date. For your convenience, the instrument adds zeros automatically. If you enter 6, for example, the time will be set to 06:00:00.

10.3. Display

All settings concerning the display are found in the submenu SYSTEM → DISPLAY. If you have a touch screen instrument, the touch screen calibration is also found in this submenu.

10.3.1. Settings

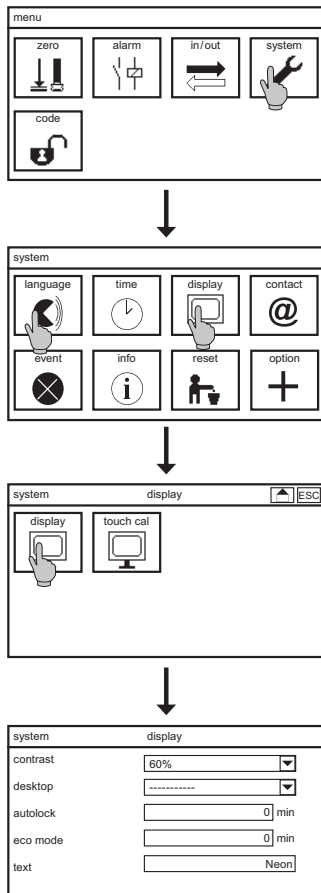

Contrast

With CONTRAST you can adjust the brightness of the display, between 0% and 100%.

Autolock

The autolock function ensures that an invalid code is set after an adjustable interval without operation, even if you have forgotten to change the code manually before leaving the instrument. Autolock sets the code back to 0000, and the display shows the desktop with the measured values. If you set the interval to 0, the autolock function is deactivated.

10. System functions

Eco mode

Eco mode turns off the display illumination after an adjustable interval. If you set the interval to 0, eco mode is deactivated, and the illumination remains on permanently.

Note **The eco mode not only saves energy, it also extends the life span of the display.**

Text

Here you can enter an identification or location, which will be shown on the left side of the top line of the desktop.

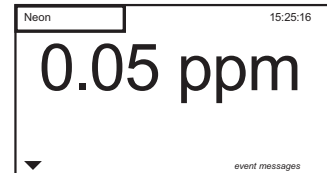

10.3.2. Touch Cal

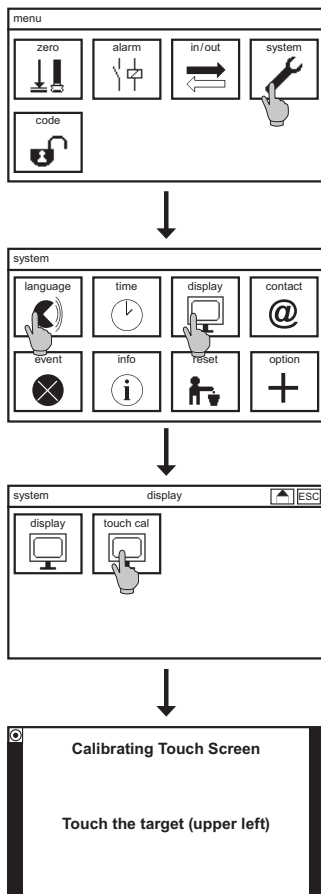

To calibrate the touch screen, select in submenu SYSTEM → DISPLAY the symbol TOUCH CAL to start the calibration. The touch screen calibration texts are available in English only.

Note When started, the calibration routine cannot be left until it is finished, it has to be carried out completely.

The routine comprises five steps. You have to touch each corner of the display, and finally the center of the displayed text.

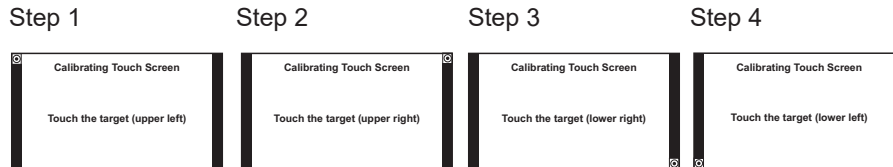

Note The touch screen calibration can also be started by touching the screen for more than 30 seconds.

10.4. Contact

In the submenu SYSTEM → CONTACT you can store contact data of your contact person, including company name, personal name, and phone number.

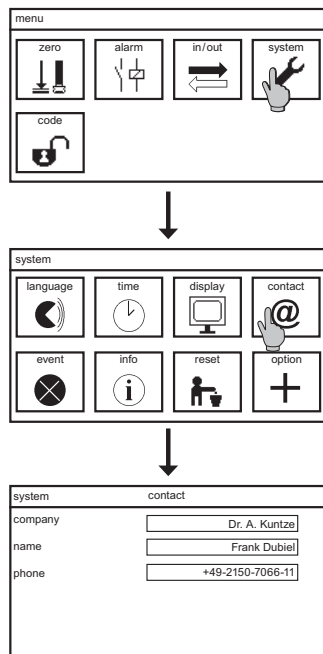

Select in the submenu SYSTEM the symbol CONTACT. For each field a keyboard opens to enter the name or number.

Note Contact data can be shown on the desktop, if you select the display design "Contact".

Note With restricted access (Code 0202) you can view this menu but not change the settings.

10. System functions

10.5. Event-related support

If an event message appears on the desktop, the submenu SYSTEM → EVENT provides information on the event and suggestions how to solve it.

Select in the submenu SYSTEM the symbol EVENT. With touch screen instruments you can reach this submenu directly by touching the event message on the desktop. If there are no event messages, the event help will only show “no active event”. If more than one event is currently indicated, you can scroll up and down to view all events.

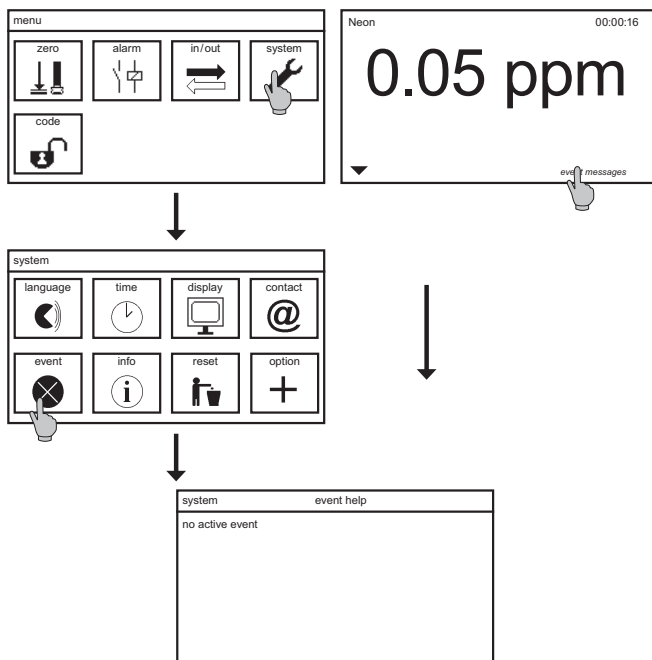

10.6. Info

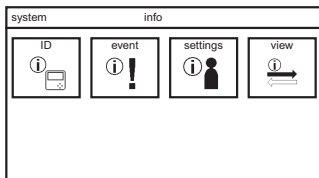
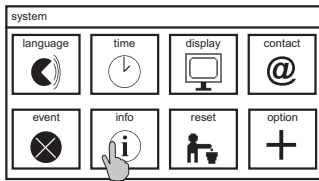
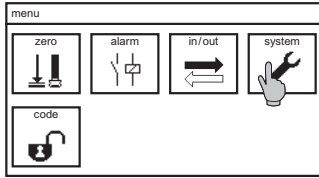

The submenu INFO is found in the submenu SYSTEM. It contains four symbols:

ID

This shows the serial number, the software version, and the operating hours of the instrument.

Eventlog

The event log stores up to 100 events, with the time they appear (*) or leave (#).

Settings

This submenu shows a complete list of all settings. Press UP and DOWN to view the complete list.

View

This submenu shows the raw signals of the sensors, the output signals of the mA outputs, and the status of the digital inputs.

Note

The analog outputs are add-ons, and are shown only if the instrument is equipped with these features.

10. System functions

10.7. Reset to factory settings

The reset resets all settings to factory settings, except the time, date, and contact. Activated add-ons will remain activated, of course.

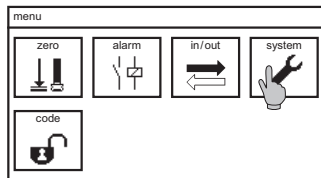

Select the symbol SYSTEM in the main menu, and in the submenu the symbol RESET.

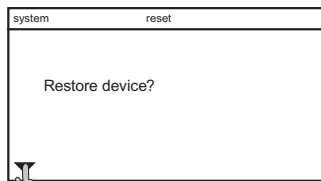
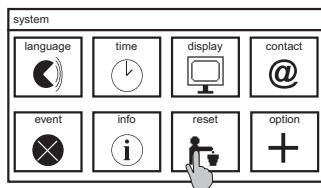

Go DOWN as indicated.

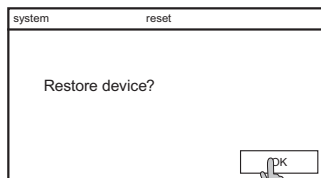

Acknowledge with OK.

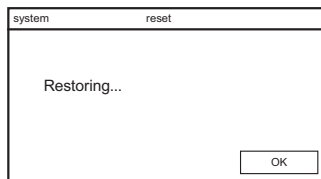

All settings are reset, and the instrument initializes.

Note The touch screen has to be calibrated after reset. The calibration routine starts automatically.

10.8. Add-on activation

In this menu you can activate add-ons. Enter the 4-character code you have received with the purchase to add one or more of the following features:

- > Analog output
- > Second analog output
- > Data log
- > Modbus RTU (RS 485) – needs additional hardware

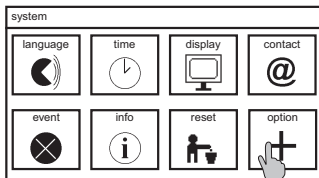
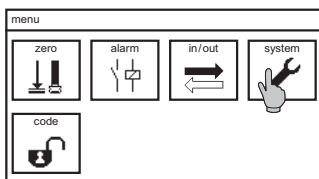

To activate add-ons, select the symbol SYSTEM in the main menu, and in the submenu the symbol ADD-ON.

A keyboard appears to enter the code.

Note **The input is case-sensitive! Observe capital and small letters.**

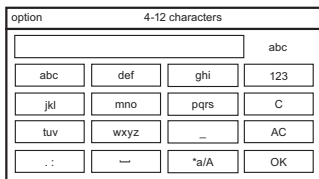

After a successful activation, the display shows which features have been activated, and the instrument initializes. If the entered code was incorrect, no message appears, and the previous settings are maintained.

Note **We recommend to reset all settings to factory settings after activating add-ons.**

11. Alarm relay

11. Alarm relay

11.1. Settings

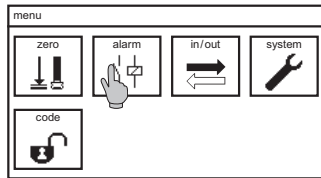

Select the symbol ALARM in the main menu.

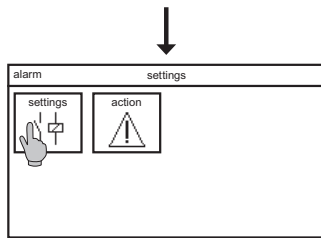

In the submenu, select the symbol SETTINGS.



Here you can set the following parameters:

Delay R1, R2, and R3

This defines a delay time – in case of an event, the alarm relay switches only after a specified interval. Display of the text message on the desktop and output of 22 mA error current are not affected by this setting and will occur immediately. This function is only available for relay 3.

Function

Here you can turn the normally open contact into a normally closed contact. That means that the relay is actively closed in case of normal operation and opens in case of alarm – with the advantage that power failure also leads to an alarm.

Limit 1/limit 2

You can define an upper and a lower limit for each measurement. If the measured value is higher than limit 1 relay 1 is switches, if the measured value is higher than limit 2 relay 2 switches. Additional alarm can be issued via alarm relay - if you have specified the limits as alarm actions.

11.2. Alarm action

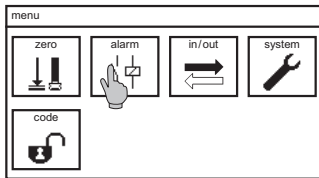

Select the symbol ALARM in the main menu.

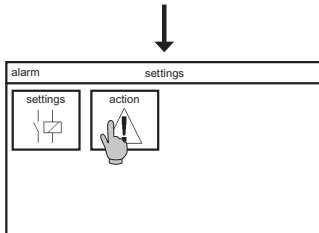

Select the symbol ACTION.

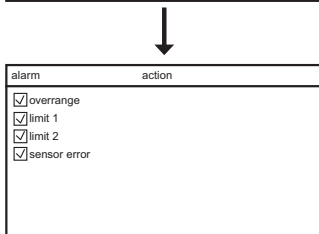

A list of all possible actions appears.

By activating the check boxes you can define actions as alarm actions. If a box is marked with a tick, the action or event will cause the alarm relay to switch. An empty box means that the action or event does not cause the alarm relay to switch. Overrange refers to both inputs, the message and alarm will occur if either input is affected.

Note If an action concerns an add-on that you have not activated, the box is crossed out and cannot be selected.

The following events always cause the alarm relay to switch:

- > Communication error
- > Unknown measuring module

12. Add-on Datalog

Note The symbols DATALOG and STATUS are shown only if the add-on datalog has been activated.

Note The Microsoft FAT (FAT16) file system root folder can manage a maximum of 512 entries. The use of long file names can significantly reduce this number of available entries. Always use an empty SD-Card or a SD-Card with limited entries in the root folder and an appropriate directory structure.

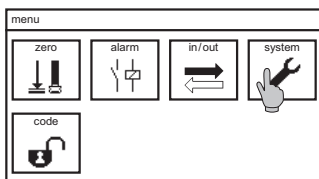

Select the symbol IN/OUT in the main menu, and in the submenu the symbol MEMORY.

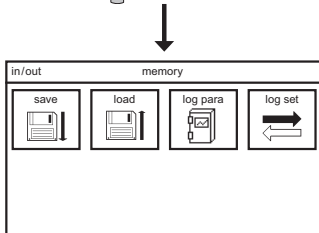
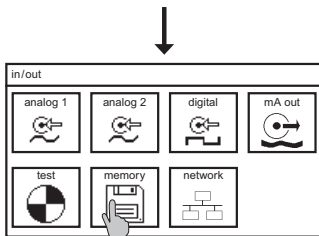

If the datalog add-on is activated, four symbols appear. In the menu LOG PARA you define which parameters you want to log. In LOG SET you define interval and log mode, and view the log status.

Log para

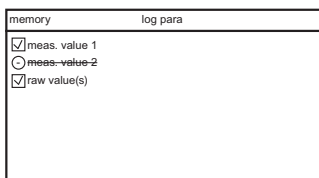

You decide which parameters are logged. Tick the boxes to log the parameter.

Log set

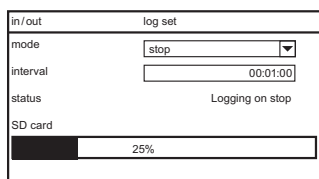

In the submenu LOG SET you can make the following settings:

Mode

Start data logging by setting the mode to either stop or ring. Stop means that the logging stops when the card is full. Ring means that when the card is full, the oldest data will be overwritten.

Note **Never remove the SD card while the logging is running! Always set the mode to OFF (not stop!) before removing the card. Otherwise data loss might occur, and an error message will appear.**

Note **Always use a card with sufficient storage space, even with ring mode, otherwise the logging will not start.**

Interval

The INTERVAL defines the time between subsequent datalogs. You can enter an interval of 1 second up to 24 hours.

Example:

00:00:01 means that each second the values are logged.

00:01:00 means that each minute the values are logged.

01:00:00 means that once every hour the values are logged.

Note **The instrument fills in zeros automatically.**
Example: 1 is interpreted as 00:00:01 / 1: is interpreted as 00:01:00 / 1:1: is interpreted as 01:01:00

12. Add-on Datalog

12.1. View logged data

To remove the SD card, first set mode to OFF, then press the SD card to take it out of the instrument.

Note If you remove the card without deactivating the logger, data loss might occur, and the instrument displays an error message.

```
1 Text::Meom
2 Device SnNr::Me0001J01 ;
3 Device SW::V 2.18 ;
4 Modul SnNr::00103;
5 Modul SW::V 02.00;
6
7
8 Mode: [Stop]
9
10 Interval: 1 sec
11
12
13 Date; Time; Measure-Value[pH]; mV-Value[mV]; Temperatur[°C];
14
15 14.09.2013;12:03:36;+6,99; +0; +25,0;
16 14.09.2013;12:03:37;+6,99; +0; +25,0;
17 14.09.2013;12:03:38;+6,99; +0; +25,0;
18 14.09.2013;12:03:39;+6,99; +0; +25,0;
19 14.09.2013;12:03:40;+6,99; +0; +25,0;
20 14.09.2013;12:03:41;+6,99; +0; +25,0;
21 14.09.2013;12:03:42;+6,99; +1; +25,0;
22 14.09.2013;12:03:43;+6,99; +1; +25,0;
23 14.09.2013;12:03:44;+6,99; +0; +25,0;
24 14.09.2013;12:03:45;+6,99; +0; +25,0;
25 14.09.2013;12:03:46;+6,99; +0; +25,0;
26 14.09.2013;12:03:47;+6,99; +0; +25,0;
27 14.09.2013;12:03:48;+6,99; +0; +25,0;
28 14.09.2013;12:03:49;+6,99; +0; +25,0;
29 14.09.2013;12:03:50;+6,99; +0; +25,0;
30 14.09.2013;12:03:51;+6,99; +0; +25,0;
31 14.09.2013;12:03:52;+6,99; +0; +25,0;
32 14.09.2013;12:03:53;+6,99; +0; +25,0;
33 14.09.2013;12:03:54;+6,99; +0; +25,0;
34 14.09.2013;12:03:55;+6,99; +0; +25,0;
```

Logged data are stored in .CSV files. The file name consists of the measuring parameter, the date, and the time.

Each file starts with the device name, the instrument number, and the software versions, followed by the log mode and the interval. Measured values are listed line by line, separated by semicolons.

CSV files can be opened with commercially available spreadsheet software such as OpenOffice Calc or Microsoft Excel or in a simple text program.

For each day, a new file is created. Additionally, a new file is created if:

- > Power was turned off
- > The measuring parameter changed
- > The logging was stopped and restarted
- > Other parameters for the datalogging were selected

13. Add-ons mA output

Up to two analog outputs are available as add-ons. As soon as at least one mA output has been activated, the symbol mA OUT appears in the submenu IN/OUT.

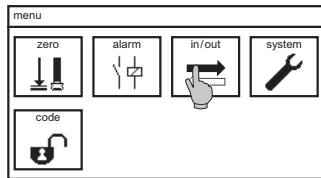

Select the symbol IN/OUT in the main menu and then select the symbol mA OUT. Here you can set the following parameters:

Assignment

Select if you want to read out via the mA output measured value 1 or measured value 2.

Range

Select either 0-20mA or 4-20mA from the drop-down list.

22 mA alarm

If you activate this function, the mA output rises to 22mA whenever the measuring inputs receive no proper signals.

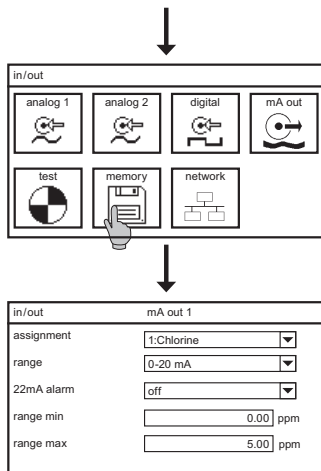

Note While 4-20mA gives slightly less resolution, it helps identifying cable breaks.

Range min and max

You can zoom by defining which measured values correspond to 0/4mA and which to 20mA. With these settings you can even invert the output, by assigning 20mA to a smaller value than 0/4mA.

Warning If you read out sensor 2 via mA output and change the settings for measuring input 2 in the ANALOG 2 menu to “No sensor” the readout of the assigned mA output is automatically reassigned to measuring input 1.

14. Add-on Modbus RTU

Neon® instruments are optionally available with a serial interface RS 485 Modbus RTU. To use this function you have to install the RS 485 circuit-board, observing the ESD-directive, and activate the software with the appropriate add-on code obtained from Dr. Kuntze.

When setting up a bus with several instruments, mind that the instruments are connected in line, not radially. Both ends of a long bus connection should be terminated with termination resistors of 120 Ohm. With the instruments, you can activate the termination via menu.

Note **Activate the bus termination only at the ends of the line. If you activate terminations somewhere inbetween, this might cause malfunction in the bus communication.**

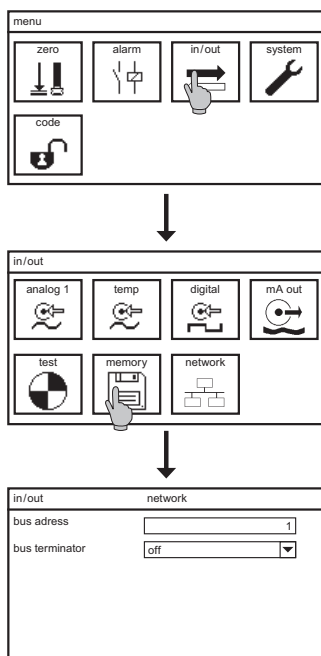

Select the symbol IN/OUT in the main menu and in the submenu, select the symbol NETWORK. Here you can set the following parameters:

Bus address

Assign a different number to each instrument in your bus system. With this number, you can address the instrument from the master instrument to read out data.

Bus termination

If you select ON from the drop-down list, the termination is activated for this instrument.

14.1. How to read out data

Request

Function code	1 Byte	0x03
Start register	2 Bytes	0x0000 to 0xFFFF
Quantity of registers	2 Bytes	1 to 125 (0x7D)

Response

Function code	1 Byte	0x03
Bytes	1 Byte	2 x N*
Register value	N* x 2 Bytes	

*N = quantity of registers

Write single register

Function code	1 Byte	0x06
Register	2 Bytes	0x0000 to 0xFFFF

Write multiple registers

Function code	1 Byte	0x10
Start register	2 Bytes	0x0000 to 0xFFFF
Quantity of registers	2 Bytes	1 to 125 (0x7D)

14.2. Communication parameters

Baudrate:	19200 bps
Data bits:	8
Stopp-Bits:	1
Parity:	even
MODBUS address:	selectable between 1 - 31, factory settings: 1

14.3. Registers

Neon® provides the following variables:

- > Measured values: measuring parameter, and raw value
- > Controller outputs: S1 and S2 for add-on controller and S1 for add-on volume based dosing
- > Status of digital inputs and outputs: digital inputs 1 and 2, relays 1-3
- > Event messages
- > Calibration results as in the Cal/Info menu
- > Instrument data incl. activated add-ons

All parameter settings can be read and most parameters can be set via the interface.

All test functions can be activated via the interface.

14. Add-on Modbus RTU

14.3.1. How to read variables

Each variable has at least three registers. The first register contains the value, the second in the lower 8 bit the number of decimal places and in Bit 8 the percentage flag, which is set if a value is expressed as percentage of a given range. In that case, the value of the first register lies within 0 (0%) and 10000 (100%). The third register contains a code indicating a unit or text – refer to table “units and texts”.

Numerical values with a limited range have two additional registers specifying the minimum and maximum value of the range.

Example for a numerical value without percentage flag:

The temperature is listed as follows:

1. register: 4160, quantity of registers: 5

If you read these five registers, the response is as follows:

Reg. 1 (4136)	Reg. 2 (4137)	Reg. 3 (4138)	Reg. 4 (4139)	Reg. 5 (4140)
250d	1d	1001d	-300d	1400d
Value	Number of decimal places	Code of unit (°C)	Minimum of range	Maximum of range

The 1 in the second register means:

- > Value and range limits have to be divided by 10 to achieve one decimal place.
- > The percentage flag is not set. Otherwise the number in the second register would be 257 (=256+1; expressed as hexadecimal value 0101h). The value is not a percentage of the range but already the true measured value.

The first register gives the value 250. This represents a temperature of 25.0 and from the third register the unit °C.

Registers four and five show the range of the temperature measurement, which is -30.0...140.0°C.

*Example for a numerical value with percentage flag:
The lower limit is listed as follows:
1.register: 6304, quantity of registers: 5
If you read these five registers, the response is as follows:*

Reg. 1 (6304)	Reg. 2 (6305)	Reg. 3 (6306)	Reg. 4 (6307)	Reg. 5 (6308)
1111d (0457h)	258d (0102h)	1422d (058Eh)	65336d (FF38h)	1600 (0640h)
Value	Number of decimal places	Code of unit (pH)	Minimum of range	Maximum of range

The 258 in the second register means:

- > Percentage flag is set, the value is increased by 256 (expressed as hexadecimal value 0102h). The value is a percentage of the range. The true value has to be calculated from the range.

- > After deducting the 256, in the second register remains a 2. Measured value and range limits have to be divided by 100 to achieve two decimal places.

Registers 4 and 5 show the range of the lower limit, which is -2.00...16.00, and the third register shows the unit pH.

The value of the first register is 1111, which is 11.11% of the range. Calculate $11.11 * (18) / 100$ and you will find that the value is 2 pH above the minimum of the range = pH 0.

Note **Text variables have 25 registers, each containing one character expressed in Ascii code. Text variables have no registers for decimal place, unit, or range.**

14.3.2. Measured values, controller outputs and status of digital inputs and outputs

For measured value and temperature, an additional HOLD-value is given out. The HOLD-Value equals the true value in the operation modes MAN and AUTO but is frozen whenever the instrument is set to HOLD. We recommend the use the HOLD-value if you have set alarm values in the PLC that you do not want to be activated during maintenance.

Note **The operation mode can be found in register 2240, refer to table “parameters”.**

Name	1. register	Quantity of registers	Type	Bytes
Measured value	4136	5	i_16	2
HOLD-value	4568	5	i_16	2
Temperature (Gas: measured value 2)	4160	5	i_16	2
HOLD-value of temperature (Gas: Hold-value measured value)	4584	5	i_16	2
Raw value Measuring input 1	4440	3	i_16	2
Raw value Measuring input 2	4648	3	i_16	2
Add-on controller: controller output S1	6848	5	i_16	2
Add-on controller: controller output S2	7128	5	i_16	2
Add-on volume based dosing: controller output S1	7296	5	i_16	2
Status digital input 1	6152	3	u_8	1
Status digital input 2	6184	3	u_8	1
Status relay 1 (controller)	6544	3	u_16	2
Status relay 2 (controller)	6568	3	u_16	2
Status relay 3 (alarm relay)	6592	3	u_16	2

14. Add-on Modbus RTU

14.3.3. Event messages and calibration results

Up to 100 event messages (current and logged) as well as the up to 10 logged calibration results of the Cal/Info menu are available via interface.

The index (registers 200 and 100) shows which entry is the first.

The time has three registers: Day+month contains the day in the upper 8 bits and the month in the lower 8 bits. Year+hour contains the year in the upper 8 bits and the hour in the lower 8 bits. Minute+second contains the minutes in the upper 8 bits and the seconds in the lower 8 bits.

For event messages, a code indicates the nature of the event – refer to table „event codes“.

Name	Register	Type	Bytes
Event log, index first entry	200	u_8	1
first entry day + month	201	u_16	2
first entry year + hour	202	u_16	2
first entry minute + second	203	u_16	2
first entry code (refer to the following table)	204	u_16	2
second entry day + month	205	u_16	2
...			
100. entry code	600	u_16	2
Calibration log, index first entry	100	u_8	1
first entry day + month	101	u_16	2
first entry year + hour	102	u_16	2
first entry minute+second	103	u_16	2
First entry slope	104	u_16	2
First entry zero-point	105	u_16	2
second entry day + month	106	u_16	2
...			
10. entry zero-point	150	u_16	2

Table event-codes

Code	Event
1, 2	Memory fault
5	Start
10, 11, 13, 14 - 18 and 45	Internal error
20	No communication with the measurement module
25	Unknown measurement module
30	Check measuring input
35	Check temperature input Gas: Check measuring input 2
40	Out of measuring range (below range)
41	Out of measuring range (above range)
49	Zero-point
50	Slope
51	Slope C-value invalid
52	TDS factor invalid
53	Check wiring of analog input 1
54	Sensor test failed measuring input 1 (Gas)
55	Sensor test failed measuring input 2 (Gas)
56	No sensor measuring input 1 (Gas)
57	No sensor measuring input 2 (Gas)
58	Wrong sensor measuring input 1 (Gas)
59	Wrong sensor measuring input 2 (Gas)
60	No SD card for saving
61	No SD card
62	SD card: write error
63	SD card: read error
65	SD card: invalid format
66	SD card: load error
70	SD card: logger stopped
82	Lower limit

14. Add-on Modbus RTU

Code	Event
83	M1 limit value 1 (Gas)
84	M1 limit value 2 (Gas)
85	Lower limit
86	M2 limit value 1 (Gas)
87	M2 limit value 2 (Gas)
90	Dosage check
92	Digital input 1 „no water“
93	Digital input 1 „level“
94	Digital input 1 „External Stopp“
95	Digital input 1 switched (Gas)
96	Digital input 2 „no water“
97	Digital input 2 „Behälter leer“
98	Digital input 2 „External Stopp“
99	Digital input 2 switched (Gas)
105	Relay 3 (alarm relay)
115	mA 1 out of range
116	mA 2 out of range
118	Sensor test measuring input 1 (Gas)
119	Sensor test measuring input 2 (Gas)
120	Calibration
121	Start delay controller
122	Start delay cleaning
123	Cleaning
124	Cleaning – base load dosing

Note For events listed as „going“ in the eventlog, the numerical value is increased by 126.

14.3.4. Instrument data

Via the interface, all information on the instrument is available, including which add-ons are activated (read-only). Information on the measurement module and the add-ons are coded as 32-bit, refer to tables “Add-ons” and “Measurement module type”.

Name	Register	Quantity of registers	Type	Bytes
Serial number	1024	12	string	24
Hardware version	2464	4	u_32	4
Production date	2448	4	u_32	4
Activated add-ons	2128	4	u_32	4
Software version	1056	10	string	20
Operating hours	2080	4	u_32	4
Measurement module				
Type	2088	4	u_32	4
Serial number	4272	3	u_16	2
Software version	4280	3	u_16	2
Hardware version	4304	3	u_16	2

Table activated add-ons (register 2128)

The add-ons are coded as 32-Bit value as follows:

Bit number	Option
17	Add-on Second digital input
18	Add-on First analog output
19	Add-on Second analog output
20	Add-on Controller
21	Add-on volume based dosing
22	Add-on Modbus RTU
24	Add-on datalog
25	Add-on ASR®

14. Add-on Modbus RTU

Table measurement module type (register 2088)

The measurement module type is coded as 32-Bit value as follows:

Bit number	Option
10	Module pR
11	Module DIS
12	Module EC
13	Module EC IL
14	Module GAS
15	Module Standard

14.3.5. How to read and write parameter settings

Parameter registers are similar to the registers described above, but here you can change the settings via interface. Mind the ranges and the percentage-flag – if a variable is expressed as percentage of a range, a new value must also be expressed that way. Besides the percentage calculation, the range indicates what values are possible for a variable. Since the ranges can change according to settings or selections, the range has to be read prior to writing, to get the range, the percentage-flag setting, and the number of decimal places.

Text variables contain one character per register, in ASCII code. Mind the maximum text length.

Note **The parameters are listed in the order of their description in this manual, i.e. Code, Mode, IN/OUT, System, Alarm, and Add-ons. Mind that not all parameters listed are available in your instrument, according to settings and activated add-ons.**

Digital inputs	1. register	Quantity	Type	Bytes	Read/ write	range
Code	2096	8	u_32	4	no	yes
Operation mode	2240	3	u_8	1	yes	no
Settings for the measurement:						
Parameter: pR						
Buffer 1	4400	5	i_16	2	yes	yes
Buffer 2	4408	5	i_16	2	yes	yes
Internal buffer	4416	5	i_16	2	yes	yes
Connection	4336	3	u_16	2	yes	no
Measure	4552	3	u_8	1	yes	no
Averaging	4328	3	u_16	2	yes	no
Parameter: DIS						
Measure	4464	3	u_16	2	yes	no
Unit	4616	3	u_8	1	yes	no
Measuring range	4536	3	u_16	2	yes	no
Averaging	4328	3	u_16	2	yes	no
Cleaning	4624	5	u_8	1	yes	yes
Start time	4632	4	u_32	4	yes	no
Start date	4648	4	u_32	4	yes	no
Base-load	4640	3	u_8	1	yes	no
Parameter: EC IL and EC						
Measurement	4464	3	u_16	2	yes	no
Measuring range	4536	3	u_16	2	yes	no
Averaging	4328	3	u_16	2	yes	no
C-value	4664	5	u_16	2	yes	yes
TDS unit	4616	3	u_8	1	yes	no
TDS factor	4656	5	u_16	2	yes	yes

14. Add-on Modbus RTU

Digital inputs	1. register	Quantity	Type	Bytes	Read/ write	range
Parameter: GAS						
Measurement analog 1	4464	3	u_16	2	yes	no
Slope analog 1	4496	5	u_16	2	yes	yes
Sensor test analog 1	7544	5	i_16	2	yes	yes
Measurement analog 2	4688	3	u_16	2	yes	no
Slope analog 2	4504	5	u_16	2	yes	yes
Sensor test analog 2	7552	5	i_16	2	yes	yes
Temperature compensation						
Mode	4352	3	u_16	2	yes	no
Sensor type	4360	3	u_16	2	yes	no
Reference temperature	4376	5	u_16	2	yes	yes
Correction	4384	5	i_16	2	yes	yes
Manual value	4392	5	i_16	2	yes	yes
Temperature compensation	4672	3	u_16	2	yes	no
Temperature coefficient (DIS / EC)	4472	5	u_16	2	yes	yes
Digital inputs						
Dig. input 1 event	6176	3	u_8	1	yes	no
Dig. input 1 contact	6168	3	u_8	1	yes	no
Option: Add-on dig. input 2 event	6208	3	u_8	1	yes	no
Option: Add-on dig. input 2 contact	6200	3	u_8	1	yes	no
System						
Language	2200	3	u_8	1	yes	no
Time	0	2	u_32	4	yes	no
Displaycontrast	2208	3	u_8	1	yes	no
Desktop design	2216	3	u_8	1	yes	no
Autolock time	2224	5	u_8	1	yes	yes
Eco-mode time	2232	5	u_8	1	yes	yes

Digital inputs	1. register	Quantity	Type	Bytes	Read/ write	range
Text	1216	10	string	50	yes	no
Company	1120	12	string	50	yes	no
Name	1152	12	string	50	yes	no
Phone	1184	12	string	50	yes	no
Alarm						
Lower limit	6304	5	i_16	2	yes	yes
Upper limit	6312	5	i_16	2	yes	yes
Gas: M1 limit value 1	7560	5	i_16	2	yes	yes
Gas: M1 limit value 2	7568	5	i_16	2	yes	yes
Gas: M2 limit value 1	7576	5	i_16	2	yes	yes
Gas: M2 limit value 2	7584	5	i_16	2	yes	yes
Alarm relay function	6320	3	u_8	1	yes	no
Alarm delay	6328	5	u_16	2	yes	yes
Gas: delay relay 1	7520	5	u_16	2	yes	yes
Gas: delay relay 2	7528	5	u_16	2	yes	yes
Gas: delay relay 3	7512	5	u_16	2	yes	yes
Alarm action	6336	4	u_32	4	yes	no

The alarm action list (register 6336) is coded as 32 Bit-value as follows:

Bit number	Alarm action
0	Dig. input 1 / Gas: sensor error
1	Dig. input 2 / Gas: sensor error
4	Zeropoint
5	Slope
6	Ovrange
8	Lower limit / Gas: limit value 1
9	Upper limit / Gas: limit value 2
12	Dosage check

14. Add-on Modbus RTU

Activated add-ons

Register 2128 indicates which add-ons are activated, as recently described.

Dependent on that, some or all of the following parameters are available:

Name	1. register	Quantity	Type	Bytes	Read/ write	Range
Add-on: datalog						
Interval	6488	8	u_32	4	yes	yes
Mode	6496	3	u_8	1	yes	no
Logparameter Meas. value/ Gas: measured value 1	6504	3	u_8	1	yes	no
Logparameter Temperature/ Gas: measured value 2	6512	3	u_8	1	yes	no
Logparameter Raw value	6520	3	u_8	1	yes	no
Logparameter S1	7456	3	u_8	1	yes	no
Logparameter S2	7464	3	u_8	1	yes	no
Logparameter Flow	7472	3	u_8	1	yes	no
Add-on: analog outputs						
mA1 22mA alarm	6368	3	u_8	1	yes	no
mA1 range	6376	3	u_8	1	yes	no
mA1 assignment	6384	3	u_8	1	yes	no
mA1 range min.	6392	5	i_16	2	yes	yes
mA1 range max.	6400	5	i_16	2	yes	yes
mA2 22mA alarm	6432	3	u_8	1	yes	no
mA2 range	6440	3	u_8	1	yes	no
mA2 assignment	6448	3	u_8	1	yes	no
mA2 range min.	6456	5	i_16	2	yes	yes
mA 2 range max.	6464	5	i_16	2	yes	yes
Add-on: Modbus RTU						
Bus address	6608	5	u_16	2	no	yes
Bus termination	6640	3	u_8	1	yes	no

Name	1. register	Quantity	Type	Bytes	Read/ write	Range
Add-on: controller						
Start delay	6680	5	u_16	2	yes	yes
S1 control type	6704	3	u_8	1	yes	no
S1 direction R1	6712	3	u_8	1	yes	no
S1 setpoint	pH: 6720 ORP: 7392 DIS: 7488 EC: 7488	5	i_16	2	yes	yes
S1 hysteresis	6728 ORP: 7424	5	i_16	2	yes	yes
S1 p-range	6736 ORP: 7440	5	i_16	2	yes	yes
S1 integral time	6744	5	i_16	2	yes	yes
S1 differential time	6752	5	i_16	2	yes	yes
S1 dosage check	6784	5	u_16	2	yes	yes
S1 pulse type	6864	3	u_8	1	yes	no
S1 pulse-frequency	6872	5	u_16	2	yes	yes
S1 pulse-pause	6880	5	u_16	2	yes	yes
S1 pulse min	6888	5	u_16	2	yes	yes
Rel. 1 on/off	6904	3	u_8	1	yes	no
S1 motor run time	6920	5	u_16	2	yes	yes
S2 control type	6984	3	u_8	1	yes	no
S2 direction R2	6992	3	u_8	1	yes	no
S2 setpoint	pH: 7000 ORP: 7400 DIS: 7496 EC: 7496	5	i_16	2	yes	yes
S2 hysteresis	7008 ORP: 7432	5	i_16	2	yes	yes
S2 p-range	7016 ORP: 7448	5	i_16	2	yes	yes
S2 integral time	7024	5	i_16	2	yes	yes
S2 differential time	7032	5	i_16	2	yes	yes
S2 dosage check	7064	5	u_16	2	yes	yes

14. Add-on Modbus RTU

Name	1. register	Quantity	Type	Bytes	Read/ write	Range
S2 pulse type	7144	3	u_8	1	yes	no
S2 pulse-frequency	7152	5	u_16	2	yes	yes
S2 pulse-pause	7160	5	u_16	2	yes	yes
S2 pulse min	7168	5	u_16	2	yes	yes
Rel. 2 on/off	7184	3	u_8	1	yes	no
Add-on: volume based dosing						
Dosage I/I (pR/EC)	7256 (higher bits) 7257 (lower bits)	8	i_32	4	yes	yes
Pulses	7264	5	u_16	2	yes	yes
Pump output	7280	5	u_16	2	yes	yes
Concentration (DIS)	7288	5	i_16	2	yes	yes
Setpoint (DIS)	7504	5	i_16	2	yes	yes
Circulation stop delay	7312	5	u_16	2	yes	yes
Pulse type	7320	3	u_8	1	yes	no
Pulse-frequency	7336	5	u_16	2	yes	yes
Pulse-pause	7344	5	u_16	2	yes	yes
Pulse min	7352	5	u_16	2	yes	yes
Rel. 1 on/off	6904	3	u_8	1	yes	no
Rel. 2 on/off	7184	3	u_8	1	yes	no

14.3.6. Units and texts

The following table contains the codes of the units and texts of register 3 of the variables:

Code	Unit
1001	°C
1054	s
1058	min
1059	h
1211	mA

Code	Unit
1243	mV
1283	MOhm
1302	mS/cm
1342	%
1353	l/h
1422	pH
1423	ppm
1552	μS/cm
1558	mg/l
1559	μg/l
1660	Times per week
1662	g/l
1663	cbm/h
1664	nA/ppm
1993	Pulses/h
1994	l/Pulse
1995	l/l
1996	– (no unit)
Text as enumeration, variable value determines which text applies, starting with 0:	
3001	NC/NO
3002	ON/OFF
3003	pH/mV
3004	Off/low/medium/high
3005	Coax/Triax
3006	PT100/PT1000
3007	Man/auto
3008	No water/level/ext. stopp Gas: relay 1, relay 2, relay 3, relay 1 and relay 2, all relays
3009	normal
3010	4-20 mA/0-20 mA

14. Add-on Modbus RTU

Code	Unit
3011	20%/40%/60%/80%/100%
3012	----/default/SD card/contact/mA 1/mA 2/S1/S2/Relay/Flow
3013	Stop/Ring/OFF
3014	ON/OFF/P/PI/PID/3point
3015	Pulse-pause/pulse-frequency
3016	Reduce/raise
3017	1 = 0-1000/2= 0-5/4= 0-10/8= 0-20/16 = 0-30
3018	µg/l /mg/l /ppm
3019	Chlorine/Chlorine dioxide/Ozone/H ₂ O ₂
3022	no sensor, Chlorine, Chlorine dioxide, Ozone
3023	0-20 mA, 4-20 mA, 0-2000 mV
from here bit mask	
3802	0-9.999 mg/l, 0-99.99 mg/l, 0-999.9 mg/l, 0-9.999 ppm, 0-99.99 ppm, 0-999.9 ppm, 0-99.99 NTU, 0-999.9 NTU
3803	-, -, -, 0-2.000 mS, 0-20.00 mS, 0-200.0 mS, 0-2000 mS, 0-9999 ppt, 0-9999 ppm, 0-9999 ppb
3804	0-2.000 µS, 0-20.00 µS, 0-200.0 µS, 0-2000 µS , 0-2.000 mS, 0-20.00 mS, 0-200.0 mS, 0-2000 mS, 0-9999 ppt, 0-9999 ppm, 0-9999 ppb

14.3.7. Test functions

To test the installation, you can operate all relays and current outputs manually, provided that these add-ons are activated in your instrument, and define relay status and current values via interface as in the test menu.

With register Test mode you switch the test mode on and off.

Name	1. register	Quantity	Type	Bytes	Read/ write	Range
Test mode	2152	3	u_8	1	yes	no
Relay 1	6552	3	u_16	2	yes	no
Relay 2	6576	3	u_16	2	yes	no
Relay 3	6600	3	u_16	2	yes	no
mA 1	6360	5	u_16	2	yes	yes
mA 2	6424	5	u_16	2	yes	yes

15. Operation and Maintenance of Neon® GAS

15.1. Start-up

Please check before instrument start-up that the sensor elements and gas sensor holder are proper installed: the sensor ist mount approx. 30 cm above the floor - the sensing element point down. The cable of the gas sensor holder run through a separate cable tunnel.

The gas sensing elements are delivered with a short-circuit protection cap, it has to be removed before installing.

Note **Store the short-circuit protection cap of the sensor element, in case you temporary put the sensing element out of operation**

Attention **Mind that the sensor is not subject to strong wind, heat, or direct sunlight. The sensing element must never get wet!**

Turn on the power. The instrument starts with a self-check and displays first the time and then the measured values. Check the settings and parameter in the menu IN/OUT → analog 1/2. Make sure that sensor slope input is the same as indicated on the sensor label.

Before zeropoint calibration make sure that the ambient is without the measured gas and check the display of measured value, if it is not the zero make a zero point calibration. But keep in mind that some readings are caused by cross references.

Cross references Chlorine gas sensor at 20°C

Gas	Concentration	Reading
Ammonia	110 ppm	0
Bromine	1 ppm	1,0
Carbon dioxide	1 %	0
Chlorine dioxide	1 ppm	0,5
Fluorine	0,1 ppm	0,4
Hydrogen	3000 ppm	0
Hydrogen sulfide	20 ppm	0
		Exposure to H ₂ S will poison the cell, further exposure to Cl ₂ will reactivate the sensor.
Nitrogen dioxide	10 ppm	2,0
Ozone	0,25 ppm	0,5
Sulfur dioxide	20 ppm	3,0

Cross references Chlorine dioxide gas sensor at 20°C

Gas	Concentration	Reading
Alcohols	1000 ppm	0
Carbon monoxide	100 ppm	0
Chlorine	1 ppm	0,6
Hydrogen	3000 ppm	0
Hydrogen sulfide	20 ppm	-5
Ozone	0,25 ppm	0,7

Cross reference Chlorine dioxide gas sensor at 20°C

Gas	Concentration	Reading
Carbon dioxide	5000 ppm	0
Carbon monoxide	10 ppm	0
Chlorine	1 ppm	1,2
Chlorine dioxide	1 ppm	1,5
Hydrazine	3 ppm	-3
Hydrogen	3000 ppm	0
Hydrogen sulfide	20 ppm	-1,6
		Continued exposure at ppm level over more than 30 minutes might blend the sensor.
Nitrogen	100 %	0
Nitrogen dioxide	10 ppm	6

Interference factors may differ from sensor to sensor and with life time. This table does not claim to be complete. The sensor might also be sensitive to other gases.

Warning **If the zeropoint calibration is done with an extant concentration or with a reading caused by cross references the measurement is distort and a reliable measurement is not possible.**

Check the settings for alarm and the assignment of the digital inputs in the menü EIN/AUS → digital. Check the wiring and the sensor elements in the menu IN/OUT → TEST.

Check the sensor function regularly by using the automatic sensor test. Adjust the interval in the menu IN/OUT → TEST.

Make sure that measurements and safety facilities run unimpeded before leaving the instrument.

15. Operation and Maintenance of Neon® GAS

15.2. Maintenance of the measurement

Maintenance of the measurement comprises cleaning of the various components, regular testing of safety features and gaskets, regular exchange of consumables, and the regular cross-check and, if necessary, calibration of the measurement.

Note **Maintenance intervals depend on the application, the installation, the accuracy requirements etc.**

Operation	Interval suggestion
Check of the measurement	Weekly by using the automatic sensor test
Testing the safety features	2 weeks
Exchange of consumables	Six months / yearly

15.2.1. Calibration of the measurement

An expensive calibration procedure with test gases is not designated by ambient air monitoring. By start-up or sensor exchange enter the sensor slope. Over time the slope of the gas sensor elements will change but for a measurement around zero the impact is low and in case of a gas alert the concentration is normally so high, that the limit are vastly exceeded.

Note **For safety measures such as the gas monitoring systems we recommend regular replacing of the sensors after twelve month.**

The instruments checks the electric output of the sensor regularly. In case of defective or disconnect sensors the message "sensor 1/2 failed" is displayed. You need to change the sensor and enter the sensor slope indicated on the sensor label. The event will be active until a positive sensor test (manual or automatic) is carried out.

15.2.2. Zeropoint calibration

In most application a zero point calibration is not necessary. Before zeropoint calibration make sure that the ambient is without the measured gas and check the display of measured value, if it is not the zero make check the connections, the settings and the cross references before doing a zero point calibration.

Warning **If the zeropoint calibration is done with an extant concentration or with a reading caused by cross references the measurement is distort and a reliable measurement is not possible.**

15.2.3. Testing the safety features

Regularly test all safety features. Check the sensor elements regularly with the automatic sensor test. You can adjust the interval in the menu IN/OUT → ANALOG 1/2.

You can start the sensor test manually whenever you like in the menu IN/OUT → TEST.

Regularly test the function of the alarm relay and ensure that in case of an alarm, the instrument issues the alarm and the connected control center registers the alarm correctly. With the aid of the test menu, such test is easily accomplished.

15.3. Decommissioning and disposal

If you want to take the measurement out of service for a while, mind the storage conditions listed in the data sheets, especially regarding temperatures.

Store instruments, sensors, and cables in a cool, dry, and dark place, protected against dust.

If you want to dispose of the instrument permanently, mind that it contains electrical components that have to be disposed of following national directives.

15.4. Facilitating functions

15.4.1. Store and load settings via SD card

You can store your settings on an SD card and reload them anytime to ensure that the settings are not lost during maintenance.

This function can also be used to duplicate settings into other instruments of the same type and parameter or to recover your settings after a software update or an upgrade via add-on. Additionally, you can do all settings comfortably on your PC, using the Kuntze configuration software, and then load the settings into the instrument via SD card. The configuration software is available free of charge.

15.4.2. Software update via SD card

With the SD card you can also install software updates. Copy the two software files you have received from us onto the SD card (not in a subdirectory). Plug the SD card in the instruments slot, and load the files via SYSTEM → MEMORY → LOAD → SOFTWARE.

15.4.3. Test menu

During start-up, or in case of an alarm in your control center inconsistent with the measured values, the test menu will help you test the communication between instrument and control center.

In the test menu you can operate all relays manually, and set fix values for each available mA output.

The test menu can only be used in the Manual mode. The test menu is a submenu of the menu IN/OUT.

16. Trouble-Shooting

In case of an event, the Neon® instrument provides a variety of functions to assist you:

- > Event messages on the display, declaring the nature of the event.
- > An event help containing suggestions how to solve the problem.
- > An event log that stores up to 100 event messages
- > An info menu, showing all settings and current values
- > A reset function to restore factory settings
- > A diagnosis file in case that you need external help. The diagnosis file will allow your contact person to assess the situation.

16.1. Useful accessories for trouble-shooting

- > **Spare sensor element:** sensor elements are consumables, and fragile. Exchanging a sensor can speed up trouble-shooting: If the problem remains, it was probably not caused by the sensor. If it has vanished, the sensor element needs to be replaced or at least cleaned and regenerated.
- > **Spare cable and gas sensor holder:** Cable and gas sensor holder are frequently causing trouble - damaged contacts or insulations lead to malfunctions very similar to those caused by sensor defects. With a spare cable, such malfunctions can easily be identified and solved.
- > **Multimeter:** with a multimeter you can easily measure a contact between two electrodes to rule out a short-circuit or to measure the supply voltage delivered from the instrument to rule out a defect.

16.2. Contact

In SYSTEM → CONTACT you can store contact data of a contact person who might help in case of problems. With restricted access (code 0202) this data can be viewed if not altered.

16.3. Diagnosis file

In case of problems, it might be useful to provide an external contact person with an overview of the current situation. To that purpose save the diagnosis file on your SD card. It contains all current values and settings and the eventlog.

16.4. Info

The Menu SYSTEM → INFO contains all information on your instrument, the settings, and the current values, such as:

ID

Here you can find the instrument number, the software versions, and the operation hours. This information is important for repair, updates, etc.

Eventlog

The eventlog lists up to 100 events with the times of their appearance and disappearance. Further details are supplied on the following pages.

Settings

This menu lists all settings. In case of trouble, check if all settings are as you had intended, and check if the instruments behavior is consistent with the settings. If for example the alarm relay is not activated when the measured value drops below the lower limit, this might be because you have not activated the lower limit as an alarm action in the alarm action list.

View

This menu shows all current values of analog and digital inputs and outputs, including the raw signals of the sensors. The latter are invaluable for trouble-shooting since they are not affected by any user settings such as calibration, temperature compensation etc. If for example you get a slope error after calibration, even though the raw signals of the sensor were plausible, then the problem might well be a defective or missing temperature measurement, and an exchange of the Des sensor would be quite useless.

The raw data is also especially useful if the instrument has been hopelessly miscalibrated. The information on mA output values and status of the digital inputs help locating communication problems with the control center. mA values can be measured at the terminals of the instrument with an amperemeter.

Note **The mA outputs are add-ons. They are displayed only if the functions have been activated.**

16.5. Event messages

In case of trouble, the instrument displays an event message on the desktop. If there are more than one message, they are displayed alternately.

Not all events will cause the alarm relay to switch. For many events you can decide for yourself if the relay should switch by defining the event as an alarm action in the alarm action list – see Alarm relay.

16. Trouble-Shooting

16.6. Eventlog

Up to 100 events are saved in an eventlog. The *-sign indicates appearance, the #-sign disappearance. Besides the event messages, this also lists power interrupts, calibrations, and similar operations, with date and time.

This helps to interpret events – for example a deviation of the measured value shortly after a power interrupt may simply be due to the unfinished polarization of the measurement.

The eventlog provides information on frequency and duration of events. You can see what events have occurred in the past, and how long they lasted. The appearance and disappearance times allow to check what other events had happened at that time, for example the start-up of a dosing pump, frequency inverter, etc.

Note **You can save the eventlog by saving the diagnosis file.**

16.7. Event help

As an addition, the instrument provides help for all events: information on possible causes, and suggestions for possible remedies. These can be found in the menu SYSTEM=>EVENT, or by touching the event message on the desktop.

We advise to follow the suggestions in the order in which they are presented.

Event message	Cause	Suggested remedies
No sensor 1/2	The measuring receive no suitable signal	There is no sensor connected to analog input 1/2 or the parameter setting is wrong.

If this message appears the instrument did not recognize the sensor or the gas sensor holder. Start with checking if the LED in the gas sensor holding is on. Therefore look into the gas sensor holder via the transparent lid. If the LED is off the gas sensor holder is probably not connected to the power supply. Check the connection between cable and instrument and check the connection between cable and gas sensor holder. If the connection is accurate and there is still no LED on, check the power supply at Neon with a multimeter: connect terminal 1 (mass) and measure with terminal 7 or 9, the output should be +6V, then measure with 8 or 10, the output should be -6V. If the power supply is accurate change the gas sensor holder or the cable.

If the LED is red, the power supply is okay, but maybe there is no or a defect sensor. Remove the sensor from the holder, check the connection pins and install the sensor again. If the LED is still red install a spare sensor element.

If the LED is green, the instruments recognize the sensor. If the message is still active check the measuring parameter setting in the menu IN/OUT->ANALOG->measurement. If necessary change the parameter.

Note **For Chlorine and Chlorine dioxide the message only occurs if you connect an Ozone sensor element.**

Event message	Cause	Suggested remedies
Check measuring input 1/2	The measuring input receives no proper signal	Check input, check sensor plug, check cable, check sensor

This message appears if the measuring input is overloaded, an indication that too strong current is detected. This could be the case at high concentrations e.g. in case of a gas alarm. After decontamination of the room change the sensor element. If the message remains without a concentration overrange, disconnect the cable vom the gas sensor holder, if the message disappear change the gas sensor holder. If the message remains, disconnect the cable from the instrument. If the message disappears now, exchange the cable.

Event message	Cause	Suggested remedies
Sensor test 1/2	The sensor test for M1/ M2 is currently running	At M1/M2 connected sensor will be checked

The instrument checks the electric output of the sensor regularly. During the test all other functions are blocked, and the message "Sensor test 1/2" is displayed.

Event message	Cause	Suggested remedies
Sensor 1/2 failed	Sensor 1/2 did not pass the automatic test	Check the connection and where required change sensor 1/2

If this message appear the electric output check of sensor 1 or sensor 2 failed. Check the connection of cable, instrument gas sensor holder and gas sensor. If everything is okay the LED is green. In this case the sensor element is defect, change it and repeat the sensor test. If the LED is red go on like deccribed by "no sensor".

Event message	Cause	Suggested remedies
M1/M2 limit value 1/2	The measured value is higher than limit 1/2	The adjusted value is exceeded relay 1/2 switches

Warning **If the zeropoint calibration is done with an extant concentration or with a reading caused by cross references the measurement is distort and a reliable measurement is not possible.**

If this event is displayed event though there is no gas concentration maybe another gas is responsible check cross references.

Note **Temporary limit exceedance that might happen regularly during normal operation can be ignored by setting a delay time in the menu Alarm relay.**

16. Trouble-Shooting

Event message	Cause	Suggested remedies
Digital input 1/2	The digital input was closed	Digital input 1/2 was closed

The message occurs if the digital input 1/2 is closed additionally the relays will be deactivated. You can define which relays will be deactivated in the menu IN/OUT → Digital.

Event message	Cause	Suggested remedies
mA out of range	The current measured value corresponds to an output outside the 0(4)-20mA range	Check settings

This message appears if the measured value is higher than the one assigned to 20mA or lower than the one assigned to 0/4mA.

Example:

You have set the mA output to 0-1mg/l. The output is 0(4)mA at 0mg/l, and 20mA at 1 mg/l. If your measured value is 1.2mg/l, this message will appear.

Check the settings for the analog outputs, and change the settings if necessary.

Finally, there are some event messages indicating fundamental problems that you cannot solve on site.

Event message	Cause	Suggested remedies
Communication error	The internal communication between instrument parts does not work	Contact your supplier
Unknown measurement module	The measurement module does not fit the instrument or does not work properly	Contact your supplier

If such a message appears, the instrument has to be sent in for repair.

16.8. Events with Popup messages

In some events, a window pops up, displaying a message. Just note its contents, or follow the instruction. To close the window, you have to acknowledge with OK.

Popup message	Cause
Check sensor and sensor settings	The measuring input is out of range (higher or lower than 50 mV).

If you try to make a zero point calibration if the raw value is higher than 50 mV or lower than -50 mV the message "check sensor and sensor settings" appears. Without a suitable measuring signal within the range a zero point calibration is not possible.

Popup message	Cause	Suggested remedies
SD card error	The instrument cannot use the SD card	No SD card Invalid format Invalid file SD card full

Check if an industry-standard SD card has been plugged into the slot, and that it was plugged properly. If you want to load settings or update files, check that the files are available on the SD card directly and not in a subfolder. Delete and restore the files, if necessary. If you want to store settings on the SD card, check if there is enough storage space left on the card.

This message appears also if you remove the card without deactivating the logger first.

Popup message	Cause	Suggested remedies
No appli	The software files cannot be loaded	Please renew the 2 data files on the SD card and try again.

For updates, both files have to be stored on the SD card, not in a subfolder. Check that the files are available, and delete and restore them if necessary.

Popup message	Cause	Suggested remedies
Memory stop data logging	The SD card is full.	SD card full, data logging stopped.

If you have set the logger to STOP mode, then the instrument stops the logging when the SD card is full.

Change the SD card, or remove some of its contents, or select the mode RING to overwrite older data.

16. Trouble-Shooting

16.9. Reset

As a last resort it is sometimes necessary to restore factory settings. With the RESET function you erase all settings by operators. Activated add-ons will of course remain activated.

With the Reset function, the system is set to a defined condition. User settings that might severely impede an evaluation of the measured values, such as a calibration gone wrong, are erased.

Index

A		Code	23
Access level	17	Communication error	74
Add-on activation	41	Connection diagram	14
Alarm relay	42	Contact	
action list	43	data contact person.....	37
function	42	Contact (digital input)	27
settings	42	Contrast (display)	35
Analog input	25	Cross references	26
Analog output	47		
0/4-20mA selection	47	D	
22 mA alarm.....	47	Datalog	44
assignment.....	47	interval.....	45
range	47	start	46
range min/max.....	47	view	46
Autolock	24, 35	Decommissioning	69
		Desktop	17
C		Diagnosis file	70
Calibration	68	Digital input	
info	26	assignment.....	27
menu	26	contact.....	27
touch screen.....	36	event message	71
zeropoint.....	26	Dimensions	11
Calibration level code	24	Display	35
Check measuring input	73	Disposal	69

Index

E	
Eco mode	36
Event help	72
Eventlog	72
Event messages	71
Event-related support	38
F	
Facilitating functions	69
Factory settings	40
Features	6
Full access code	24
I	
Info	
calibration	26
menu	39
Installation	11
panel-mounted housing	11
wall-mounted housing	12
Interval (auto test)	69
Interval (datalog)	44
L	
Language	34
Load settings	29
Load Software	32
Log para	44
Log set	44
M	
Maintenance	66
mA out of range	74
mA output	47
22 mA alarm	47
Measurement	25
Memory	29
Memory stop data logging	75
Menu overview	21
Mode (data log)	45
N	
No appli	75
No sensor	72
O	
Operating hours	39
Operation	17
P	
Popup messages	75

R	
Range (mA outputs)	47
Raw signals	71
Registration range (mA outputs)	47
Reset	40
Restoring factory settings	70
S	
Save	
diagnosis file	33
settings	31
SD card	30, 16
SD card error	75
Sensor test	25, 73
automatic.....	73
interval.....	25
M1/ M2.....	73
manual.....	68
Serial number	39
Settings	
alarm relay.....	42
datalog.....	44
display	35
how to load	31
how to save	30
menu	17
overview	39
store and load.....	29, 69
Software update	32, 69
Software version	39
System functions	34
T	
Technical Data	10
Test menu	69, 28
Text	36
Time	34
Touch calibration	36
Touch screen operation	17
Trouble-Shooting	70
U	
Unknown measurement module	74
V	
View	71
raw signals	39
W	
Warranty	7
Z	
Zoom (mA output)	47



Kuntze Instruments GmbH
Robert-Bosch-Str. 7a
40668 Meerbusch | Germany

+49 2150 70660
info@kuntze.com
www.kuntze.com

Version 2019/04